

9.1.2. GT CATEGORY SPECIFICATIONS

These specifications are part of the SCCA GCR, and all automobiles shall conform with GCR Section 9.

A. PURPOSE

The GT Category is intended to provide the membership and interested manufacturers with the opportunity to compete in purpose built, highly modified replicas of series produced automobiles. To that end, cars shall be classified in GT Classes based on their competitive potential. The Club may alter or adjust specifications and require, permit, or restrict certain specific components to equate competitive potential.

B. INTENT

It is the intent of these rules to allow modifications useful and necessary in the construction and preparation of an extremely high performance road racing vehicle. It is understood that such a vehicle can be updated and/or changed from marque-to-marque, based on member interest and manufacturer incentive. With this in mind, the Club will use the following guidelines in the determination of the suitability for classification in the GT Category:

1. Basic vehicle size, shape, engine displacement, and cylinder head design of the standard and/or alternate engine(s).
2. Member interest.
3. Manufacturer interest and potential support to competitors.
4. Vehicle production quantities of no less than 3000 units of the specified make/model within a twelve (12) month period, all such units being approved by the EPA and DOT for sale in the United States (Production Cars that have been reclassified into the GT Category need not meet minimum production quantities).

C. SPECIFICATIONS

The SCCA shall publish the GT Category Specifications (GTCS) containing recognized specifications for each car eligible to compete in the GT Category during the calendar year. Cars shall be listed according to the manufacturer's make and model designation. In the case of doubt involving specifications not adequately described in the GTCS, Scrutineers/Stewards may refer to maintenance manuals, spare parts books, general catalogs and performance catalogs published by the vehicle manufacturer, MVMA specifications, and FIA Homologation Certificates for the make and model, or may inspect other cars of the same make and model.

1. GT Category automobiles shall be divided into Classes based on relative performance as follows: GT1, GT2, GT3, and GTLite.
2. Cars may be updated or backdated within the specifications of the recognized make and model as listed on the Approved Automobile List of the GTCS (GT-1), or as listed on a single GT Specification Form line of the GTCS. Any classified engine may be used in a classified chassis within the same manufacturer as shown on the specification line.
3. Cars shall meet or exceed their minimum specified weight, as listed in the GTCS, as qualified or raced, with driver.
4. No permitted component/modification shall additionally perform a prohibited function.
5. Turbocharging/supercharging is not permitted.

9.1.2. Grand Touring Category Specifications

6. Construction of tube frame cars is permitted. Standard maximum track dimensions for all cars, unless otherwise noted, are as follows:

GT-1	70.0" F & R
GT-2	64.0" F & R
GT-3 / GT-Lite	60.0" F & R

D. AUTHORIZED MODIFICATIONS (GT-1)

1. Engine (GT-1)

a. Component Modification

1. It is permitted to lighten, balance, or modify in shape, by any mechanical or chemical means, the standard, optional, or alternate components of the engine, provided it is always possible to positively identify them as such.
2. Material shall not be added to these components unless specifically authorized by these rules.
3. The original direction of engine rotation shall be retained.

b. Induction System

1. All inducted air shall pass through the throttle venturis.
2. The specified carburetor(s) or specified fuel injection may be modified. The number, model, type, throttle bore and/or venturi restriction shall remain as specified. Refer to Section E.1.a. of these rules for additional induction specifications.
3. Any air filter(s), velocity stack(s), and or air box(es) may be fitted. Air may be ducted to the carburetor or fuel injection provided that the ducting is completely contained within the engine compartment and that the air to be ducted is supplied through normal (or as specifically authorized herein) openings in the bodywork. Cars may duct air to the carburetor airbox through an opening in the back of the hood, rectangular in shape, maximum width of 20 inches, maximum length of 3.5 inches.
4. Intake manifolds are unrestricted.
5. Any throttle linkage may be used. All throttle linkages shall be equipped with more than one system of positive throttle closure

c. Fuel System

1. Any fuel line(s) may be used. All fuel line(s) passing through the driver/passenger compartment shall be made of metal braided hose with AN-Series threaded couplings.
2. Any fuel pump(s), filter(s), and pressure regulator(s) may be used. Such components may not be located in the driver/passenger compartment, but their location within the bodywork of the car is otherwise unrestricted.

d. Emission Equipment

1. Exhaust emission control equipment shall be removed in their entirety. When air injection nozzles are removed from a cylinder head, the resultant holes shall be completely plugged.

e. Cylinder Heads

1. The standard production, optional, or specified alternate(s) cylinder head(s) shall be used. Any valve guides and valve seats may be used.
2. Material(s) may be added to the combustion chamber(s) and interior ports/passages of the cylinder head(s). The addition of such material(s) shall not enable the combustion chamber and/or interior ports/passages to be moved external to the original physical limitations of the cylinder head(s).
3. V-6 and V-8 General Motors engines are permitted: Buick, Chevrolet, Oldsmobile, Pontiac, Brodix, Brownfield, Dart, Edlebrock, Pro Action 14-degree, or Airflow Research 210, 215, 220, and 227 cylinder heads of cast iron or aluminum. All Pro cylinder head, part # 270-LM-13 is permitted. Any cylinder head(s) utilized shall be of a conventional design (siamesed intake ports, two (2) valves per cylinder, all valves inline), direct replacement type. General Motors SB-2 cylinder heads are permitted.
4. V-6 and V-8 Ford engines are permitted: Ford Motorsports SVO inline-valve or canted-valve cylinder heads of cast iron or aluminum. Alternate cylinder heads from Airflow Research, Brodix, Cylinder Head Innovations, Dart, Edelbrock, Pro Action, and World Products. Any alternate cylinder head(s) utilized shall be of a conventional design (two valves per cylinder, all valves inline) direct replacement type.
5. V-6 and V-8 Chrysler engines are permitted: MOPAR Performance conventional design (siamesed intake ports, two (2) valves per cylinder, all valves inline), direct replacement cylinder heads.

f. Camshaft and Valve Gear

1. Any camshaft(s) mounted in the standard location(s) may be used. Any cam followers may be used. Springs and mounting hardware which act directly on the cam followers may be added.
2. Camshaft drive mechanism is unrestricted.
3. Push rods, rocker arms, and rocker arm supports are unrestricted.
4. Valves are unrestricted.
5. Valve springs, retainers, keepers, and seals are unrestricted.

g. Block

1. The standard production, manufacturer's heavy duty (of the same basic materials as the original block), or specified alternate engine block shall be used.
2. The block may be bored and/or sleeved to achieve the correct displacement.
3. The block may be machined, and O-rings may be added to replace or supplement the head gasket(s).
4. The crankshaft main bearing caps may be substituted. Additional main bearing caps and/or bolts may be used provided that no material is added to the block for their attachment.

h. Pistons and Rods

1. Pistons and piston pins are unrestricted. The compression ratio is unrestricted.
2. Connecting rods are unrestricted, provided that they are made of a ferrous material, e.g., steel. Aluminum, titanium, graphite, etc., rods are prohibited.

i. Crankshaft and Flywheel

1. The crankshaft is unrestricted, provided it is made of the same basic material as the standard production crankshaft. Those vehicles originally equipped with an iron crankshaft may use a steel crankshaft. All alternate crankshafts shall retain the same angle(s) of crank throws as the original crankshaft.
2. The use of any crankshaft vibration damper is permitted.
3. The use of any flywheel and clutch is permitted.

j. Oiling System

1. The use of any oil pan (sump), oil pump(s), and/or oil pickup(s) is permitted. Oil pump(s) shall be mechanically driven by the engine. Dry sump systems are permitted. Any oil tank(s) used by such a system shall be located within the bodywork, and any oil lines utilized within the system shall be metal or metal braided, equipped with AN-Series threaded couplers.
2. The use of any oil filter(s) is permitted.
3. The oil tank(s), cap(s), oil filter(s), and any fittings attached thereto shall be isolated by a metal bulkhead(s), so that in the event of any spillage, leakage, or failure, oil will not reach the driver.

k. Electrical System

1. The use of any driver operated electrical starter is permitted.
2. The use of any ignition system (except magneto ignition) is permitted, provided the number of spark plugs remains the same as that of the standard production, optional, or alternate cylinder head(s). Driver controlled adjustable spark timing is prohibited.
3. The remaining components of the engine electrical system are unrestricted.

l. Exhaust System

1. The components of the exhaust system are unrestricted. Refer to sections D.8.c.2., and D.8.j.3., of these rules for additional exhaust system and bodywork specifications.

m. Other Engine Components

1. Alternate engine components considered replacement parts, such as seals, bearings, water pumps, nuts, bolts, studs, washers, and gaskets are permitted. Bushings or offset keys of unrestricted origin may be installed.
2. Generator/alternator, crankshaft, and water pump pulleys are unrestricted.
3. Engine mountings are unrestricted.
 - A. Cars with the engine mounted longitudinal to the chassis may relocate the engine in a longitudinal direc-

tion, centered along the longitudinal centerline of the vehicle as defined by the track. A one (1) inch transverse deviation tolerance from the absolute centerline is permitted. Unless otherwise so fitted in its standard production location or specifically authorized in the vehicle's GTCS specifications, said relocation shall align the center of the foremost spark plug hole with the front axle centerline.

- B. Transverse mounted engines may be relocated for axle/CV joint alignment. Alternately, they may be relocated to a longitudinal position if authorized specifically by the GTCS.
- C. General Motors, Ford, and Chrysler front mounted V-6 engines may be positioned so that the center of the foremost spark plug hole is no more than 4.5 inches behind the front axle center line (bellhousing and transmission locations are the same as a V-8 motor).

2. Engine, Rotary Piston (GT-1)

a. Component Modification

- 1. Rotary piston engines in GT-1 may be prepared using GTCS specifications D.1.a., b., c., d., j., k., l., and m.
- 2. The standard production or specified alternate rotor housings shall be used. No changes in the epitrochoidal curve of the motor are permitted.
- 3. The capacity of the working chamber(s) shall not be changed.
- 4. The eccentric shaft may be replaced with another of the same basic material, but no changes in its eccentricity or bearing journal dimensions are permitted.
- 5. The rotor(s) is/are unrestricted, provided the material and number of lobes remains unchanged.

3. Cooling System (GT-1)

a. Radiator

- 1. Any water radiator is allowed, provided that there are no changes to the exterior bodywork to accommodate its use. It shall not be located in the driver/ passenger compartment. Radiator overflow line(s) shall terminate in a catch tank.
- 2. Separate expansion or header tank(s) are permitted. Any such tanks shall not be located in the driver/ passenger compartment.
- 3. The heater core and all attendant heater controls, lines, and accessories may be removed in their entirety, but shall not be modified or replaced.

b. Radiator Fan

- 1. The cooling fan(s) may be modified, substituted, or removed.
- 2. Electrically operated cooling fan(s) may be installed, provided it/they serve no other purpose.

c. Radiator Shroud/Ducting

- 1. The original radiator shroud may be altered, removed, or replaced.

9.1.2. Grand Touring Category Specifications

2. Sealing or shrouding the airflow area between the normal grill opening and the water radiator is permitted.
- d. **Water Pump**
 1. The water pump(s) may be replaced with any other water pump(s) mechanically driven by the engine.
 2. *Mid-engine vehicles may use an electric water pump.*
- e. **Thermostat**
 1. The thermostat(s) may be modified or replaced with blanking sleeves or restrictors.
- f. **Oil/Lubricant Coolers**
 1. The use of any engine, transmission, and differential cooler(s) is permitted, provided that it/they are mounted completely within or under the bodywork, but not in the driver/passenger compartment.
 2. Associated cooler pumps and lines are permitted for the transmission and differential coolers.
 3. Air may be ducted to said coolers only through normal openings in the bodywork. Air ducts or other openings shall be added to body parts only where specifically authorized by these rules.
 4. Air may be ducted to the rear brakes and rear mounted coolers from an interior bulkhead behind the driver. Air may also be ducted to these components from free air under the car, provided that such under car ducting does not create "ground effects."
4. **Transmission/Final Drive (GT-1)**
 - a. **Component Modification**
 1. It is permitted to lighten, balance, or modify in shape, by any mechanical or chemical means, the standard, optional, or alternate components of the transmission and final drive, provided that it is always possible to identify them as such.
 - b. **Transmission**
 1. Automatic transmissions are not permitted unless specifically authorized on a vehicle's GTCS line.
 2. Any readily available manual transmission having no more than five (5) forward speeds and an functional reverse speed may be used, provided that it is fitted in the same basic location used in the standard production automobile. Any relocation or repositioning of the transmission-to-engine dimensional relationship shall be specifically authorized by the GTCS. Sequential shifting transmissions are permitted with a 75 lb. weight penalty. Air, hydraulic or electric actuation of the gearshift mechanism is not allowed.

A functional reverse is defined as "operable by the driver from his normal seated position and capable of sustained movement of the vehicle, under its own power, in a reverse direction." A driver-operated device for locking out reverse gear may be added provided it does not prevent prompt engagement of reverse in an emergency situation.
 3. Front engine/transmission vehicles shall locate the front mounting surface of the transmission within sixteen (16)

inches of the back of the engine block.

4. Any shift linkage may be used.
5. The linkage between the clutch pedal and the clutch housing/clutch actuating mechanism is unrestricted. A mechanical linkage may be replaced with a hydraulic system.
6. Transmission mountings are unrestricted.

c. Final Drive

1. Any axle tube, final drive housing, gear ratio, limited slip or locked differential may be used. Final drive units which permit ratio changes while the car is in motion are prohibited.
2. Heavy duty propeller shaft(s) and/or drive shaft(s) may be used. A minimum of two (2) steel 360 degree "loops" shall be installed of sufficient strength to prevent the driveshaft(s) from contacting the ground in the event of shaft and/or U-joint failure. Said loops shall be located within twelve (12) inches of the front of the shaft, and as close as practical to the rear universal joint.

5. Suspension (GT-1)

a. Ride Height

1. No part of the car to the rear of the front tire opening, including the exhaust, may touch the ground when two (2) tires on the same side of the vehicle are deflated.

b. Suspension Components

1. Suspension components may be reinforced, modified, or replaced with units of alternate design, and their mounting points may be relocated. The addition or substitution of anti roll bars, camber compensating devices, and/or suspension stabilizers is permitted. If these devices or any other suspension components extend into the driver/passenger compartment, they shall be completely sealed off from said compartment by metal panels.
2. Hubs, bearings, spindles, axles, U-joints, CV joints, bushings, ball joints, and rod ends may be freely modified or substituted.
3. The wheelbase of the automobile shall not be changed or relocated in the fore/aft direction. A tolerance of +/- 2.00 inches from published specification shall be permitted unless otherwise noted in the GTCS.

c. Springs/Shock Absorbers

1. Suspension springs may be replaced with others of unrestricted origin and type.
2. Shock absorbers are unrestricted, except that the number of shock absorbers fitted shall not be changed from that of the standard production automobile.
3. Shock absorber mountings are unrestricted.

d. Suspension Control

1. The manufacturer's basic system of front suspension shall be retained, i.e., independent. Strut type front suspension may be replaced with a double A-arm type suspension.

9.1.2. Grand Touring Category Specifications

2. The manufacturer's basic system of rear suspension may be retained, i.e., independent, live axle, etc.. All forms of independent rear suspension may be replaced with a closed tube beam, live axle suspension. Cars originally equipped with live axle rear suspension shall not replace said suspension with any type of independent suspension.
 3. Automobiles originally manufactured as FWD vehicles may convert to RWD, but shall only use a closed tube beam, live axle rear suspension.
- e. Steering**
1. The front wheels only shall be steered by the driver.
 2. The type of steering is unrestricted, provided that a collapsible type of steering column is used.

6. Brakes (GT-1)

a. Brake Components

1. The use of any dual master cylinder and/or pressure equalizing device is permitted. All cars shall be equipped with a dual braking system operated by a single control. In the case of leakage or failure to any point in the system, effective braking power shall be maintained to at least two (2) wheels.
2. Servo assist braking systems are unrestricted.
3. Backing plates or shields may be removed. Brake air ducts may be fitted, provided they extend only in a forward direction, and that no changes are made in the bodywork for their installation.
4. Parking brakes may be removed.
5. The brake lines shall be steel tubing, metal braided hose, or flexible brake hose. Lines may be relocated and given additional protection.
6. Brake discs, calipers, and/or drums are unrestricted, provided that the discs or drums are mounted in the same location (e.g., outboard vs. in-board) as the standard production automobile.
7. Water spray brake cooling systems are permitted. No water cooled calipers are permitted.
8. Carbon brake rotors are prohibited.

7. Wheels and Tires (GT-1)

a. Wheels

1. Wheels shall be made of steel, aluminum, magnesium, or a combination thereof. Multi-piece wheels shall utilize mechanical fasteners (bolts, rivets, etc.) for assembly.
2. Wheels may be thirteen (13), fourteen (14), fifteen (15), or sixteen (16) inches in diameter, but all four (4) wheels shall be of the same diameter.
3. Wheels shall have a maximum width of twelve (12) inches in the front and (13) inches in the rear.
4. Centerlock or quickchange wheels are permitted.

b. Tires

1. Tires are unrestricted, except that they must meet the requirements of GCR Section 9.3.44.

8. Body/Structure (GT-1)

- a. The intent of these bodywork/configuration rules is to maintain the recognizable external features of the standard production automobile while providing for necessary safety and performance modifications.
 1. Lightening of the bodywork is permitted, but the exterior shape of the body shall not be changed except where specifically authorized herein.
 2. The method of bodywork attachment is unrestricted, and shall meet the requirements of the GCR. Section 9.3.32., "Loss of Bodywork."
 3. Maximum overall car width shall not exceed 84.75".
 4. Trans Am approved bodywork and wheelbase specifications are allowed unless otherwise specifically prohibited by these rules. Trans Am bodywork shall be in a configuration that is approved for past or present Trans Am competition.
 5. Convertible tops, sunroofs, and removable panels shall meet GCR Section 9.3.17. As of 1/1/2002, all newly classified convertible models will be required to compete with a windshield and hardtop. Convertible models classified before 1/1/2002 will be allowed to compete without a windshield and/or top, regardless of log book issue date, unless specified differently on the vehicle specification line.
 6. Two (2) hood louvers are allowed, they must be located on the hood/front fender between the radiator and the rearward edge of the hood, max. size of 20" x 10" with a minimum of five (5) slots.
- b. Any bodywork components may be fabricated of alternate material(s), provided that their shape remains as specified herein, unless specifically prohibited elsewhere in these rules.
- c. Fenders may be flared for tire clearance, provided that their shape and opening contour in horizontal projection is similar to the original opening.
 1. Modified wheel opening(s) shall not confuse the identity of the car. The fender flares shall completely cover the highest point of the tires, and may extend into the doors and bumpers.
 2. Rear fenders may have holes or slots to accommodate exhaust outlets. These holes or slots shall be below a line seven (7) inches above the bottom of the rocker panel, and shall be no wider than seven (7) inches.
 3. The inner fender panels separating the wheel wells from the engine compartment may be altered, replaced, or removed, provided that there are panels which provide total separation between the wheel wells and the driver/passenger compartment.
- d. The hood and deck lid/trunk hinges and latches may be removed. The hood and deck lid/trunk may be "molded in"

9.1.2. Grand Touring Category Specifications

with other bodywork components to create "one-piece" front and rear ends. Misalignments or modifications to create ventilation openings where none previously existed are prohibited.

The hood may be modified for clearance of an airbox, provided that such alteration does not confuse the identity of the car.

- e. Bumpers that are not an integral part of the bodywork may be removed, providing that all projecting hardware is also removed. Alternately, they may be replaced with replicas of alternate material(s). In those cases where bumpers are an integral part of the bodywork, they may be replaced with replicas of alternate material(s). Bumper bracket holes in the bodywork may be covered, provided such covering serves no other purpose.
- f. The standard grille(s) or approved facsimile(s) shall be retained, except where covered by the front spoiler or intermediate spoiler mounting device.
- g. The original angle of the windshield shall be maintained unless alternate components and/or specifications are specifically authorized in the GTCS.
- h. All cars may use a standard safety glass windshield, mounted in the stock location and at the stock angle. In addition to any other method of retention, the windshield shall be secured within the specifications of GCR Section 9.3.52., "Windshield Clips." Polycarbonate windshields such as Lexan are allowed. Alternate windshields must be of 6mm minimum thickness. Alternate material windshields must be identical in size and curvature to the original glass component. Alternate material windshields must have in addition, three (3) inner supports to prevent the windshield from collapsing inward. These supports must be 0.75" by .125" minimum straps of aluminum. Spacing between these inner supports must be eight (8) inches minimum.
- i. The rear quarter (side) and rear windows may be made of clear, transparent, and uncolored polycarbonate material having a minimum thickness of 3mm.
 - 1. Ducts may be installed in the side windows or window openings for the purpose of supplying cooling air to the driver and/or differential/transmission coolers. Air passing through the differential/transmission coolers may be exhausted through an opening identical in size and location to the rear license plate frame.
- j. Doors
 - 1. Driver and passenger door window glass or plastic shall be removed. Inside door handles, door panels, window cranks and mechanisms, and other interior trim pieces may be removed.
 - 2. The doors shall be pinned or otherwise positively fastened to prevent their opening in the event of an accident. Standard door hinges and latches may be removed, but the doors shall remain capable of being opened or removed, unless the doors are integral to the remainder of the bodywork.
 - 3. Doors may contain holes or slots to accommodate exhaust outlets. Any such openings in the door(s) shall be below a line ten (10) inches above the bottom of the rocker, and no

wider than seven (7) inches. A maximum of two (2) such exhaust openings are permitted on the door.

k. Spoilers

1. A front spoiler may be fitted. It shall not protrude beyond the overall outline of the car as viewed from above except for a front splitter that may extend up to two (2.0) inches. The spoiler shall not extend aft of the forward most part of the front fender opening (cutout), and shall not be mounted more than four (4) inches above the horizontal centerline of the front wheel hubs. Full-width bottom shrouding of the front spoiler/nosebox area (front undertray) is permitted but must be flat and can extend no farther rearward than the center of the engine harmonic balancer. Undertray may not be stepped or curved. Undertray may be angled in side view to produce a maximum height at the trailing edge of 3.25 inches above the ground.

Openings are permitted for the purpose of ducting air to the brakes, radiator, airbox and/or oil cooler(s); equal openings may be placed in the standard lower front panel directly behind openings placed in the spoiler. Joint separations need not be shown. The spoiler "pan" area forward of the leading edge of the front wheel openings shall be flat and follow, but not exceed, the line of the front fender/spoiler bottom. No components may protrude or extend below this plane.

2. The Club Racing specified rear wing or a flat plane rear spoiler may be used. If a flat plane rear spoiler is used, it shall be contiguous with the rear bodywork rearward of the rear window, and shall comply with the following:
 - A. Height: No higher than eight (8) inches, measured from the bodywork along the face of the spoiler, from the point of attachment to the top of the spoiler. In the case of a spoiler with a curved top edge conforming to the shape of the bodywork (rearview), the measurement is to be made perpendicular to the tangent of the body at the point of attachment. In the case of a spoiler mounted with a vertical mounting flange on the rear face of the bodywork, the measurement shall be made ignoring any slight amount of mounting flange exposed due to the curvature of the rear bodywork at the point of attachment.
 - B. Width and Overhang: No wider than the body, excluding fender flares, from the forward most point of the spoiler (or mounting flanges) rearward. It shall not extend rearwards of the rearmost extremity of the bodywork for the entire width of the car (when viewed vertically from above the car at any point, the spoiler shall not protrude beyond the bodywork).
 - C. Mounting: Spoilers shall be strong enough to be self supporting, and shall be mounted directly to the rear hatch, deck, or trunk lid. A mounting flange no greater than one and one-half (1-1/2) inches wide, contiguous with the bodywork (either forward facing on the top surface of the bodywork or downward facing on the rear surface of the bodywork) shall be employed. No other forward facing sheet metal supports are

permitted. Supplemental bracing may be added in the form of two (2) rods (maximum diameter one-quarter inch), mounted at least ten (10) inches inboard from the ends of the spoiler. Small rear supports may be added.

- D. Configuration: the spoiler shall be a single plane spoiler (a straight line in any vertical cross-section), uniform in height from the rear bodywork. There shall be no gaps or openings below the spoiler for its entire width. Only enough curvature (in a fore-and-aft direction as viewed from above) shall be permitted to facilitate mounting. The use of fences, end rails, Gurney lips, wickerbills, or other forward facing lips or aerodynamic devices is prohibited.

NOTE: O.E.M. rear spoilers are not permitted unless specifically listed on the vehicle's specification form.

- E. A single element, *single plane* airfoil scaled to a chord length of 10.75 inches *is permitted*. The maximum cross-sectional tolerance of the wing profile is 0.060 inch. A maximum 0.50 inch Gurney tab is allowed at the trailing edge of the wing element. The tab must be mounted 90 degrees to the upper wing surface. No air may pass between the tab and the wing. The wing end plates must fit within a rectangle measuring 11.00 inches long by 4.00 inches tall. No portion of the wing element or tab may extend beyond the perimeter of the endplate. The endplates must be mounted parallel to the vehicle centerline, and must be perpendicular to the ground. Endplates must be flat, with no curvature or Gurney tabs. The maximum width of the entire wing assembly (wing element, endplates, Gurney tab, and mounting hardware) is 72.00 inches.
- F. Wing mounting specs: The entire wing assembly must be mounted below the peak of the roof (measured at *the highest point of the roof*). Trailing edge of wing assy. must be located within an area defined by a point; 6" forward of rearmost bodywork and the rearmost bodywork (measured at vehicle centerline). Two wing mounting posts must be used, with each one located between 16"-20" inboard from end of wing. *The exposed portions of the wing posts shall not exceed 85 square inches each. Curved mounting brackets will be measured as if they're in a flat plane as viewed from the side. Mounting brackets are to be included in the measurement.* Max. wing angle from horizontal is 30-degrees.
- I. Glass/plastic headlights, front parking and signal lights, lenses, and bulbs shall be removed. Other front lighting parts and ancillaries may be removed. Headlight, front parking and signal light, and similar standard openings in the front of the car may be used for ducting air to the engine, front brakes, and/or coolers. Such ducting may pass through interior panels for these purposes.
1. The cross sectional area of a single duct shall not exceed the cross sectional area for the original (single) headlight lens.

2. It is not permitted to relocate the standard openings for headlights, parking lights, signal lights, etc.. The headlight openings shall be covered with a wire screen or a panel of an alternate material, provided that such covering does not confuse the identity of the car.
 3. The side marker light assemblies shall be removed, and the resultant openings shall be completely closed.
- m. The windshield wiper system is unrestricted.
- n. Floors
1. Driver/Passenger Compartment: The floor of the driver/passenger compartment shall maintain the basic shape and position of the original floor, i.e., flat and horizontal, relative to the car and rocker panels. It may not be curved, angled, recessed, or channeled other than as specifically authorized by these rules, and shall be made of steel and/or aluminum only.
 - A. On the passenger side of the driver/passenger compartment (only), the floor may be raised up to ten (10) inches, or a secondary floor installed at that level, to accommodate the installation of the exhaust system and mufflers. Such raising of the floor shall serve no other purpose.
 - B. The driver/passenger compartment floor shall cover the area from the forward firewall the full width between the rocker panels, and shall extend no further aft than the forward most point of the rear wheel openings. The floor panels between the rocker panels and the outboard frame rails may be cut out or removed.
 2. For front engine cars – floor panels between the engine bay firewall and the forward most point of the front wheel openings are prohibited. For mid or rear engine cars – floor panels between the engine bay firewall and the rearward most point of the rear wheel opening are prohibited.
 3. The fuel cell bottom and/or floor behind the rear wheel opening shall be flat, angled upwards, and shall follow, but not exceed, the line of the rear fender bottom.
- 9. Driver/Passenger Compartment - Trunk (GT-1)**
- a. **Seating**
 1. All standard production seats and seat backs shall be removed. The driver's seat shall be replaced with a one-piece bucket-type race seat. Such seat shall be installed so that a second seat of the same dimensions could be simultaneously fitted to the passenger's side of the car (no center seating).
 - b. **Steering Wheel**
 1. Any steering wheel and wheel quick release mechanism complying with GCR Section 9.3.41., may be used.
 - c. **Gauges/Accessories/Driver Convenience**
 1. The replacement, addition, or removal of accessories (gauges, switches, indicators, etc.) is permitted. Such installations and/or modifications shall have no influence on the mechanical performance of the car. Similarly, they shall not include the substitution or replacement of any element of the bodywork or chassis except where speci-

cally authorized by these rules.

2. Fresh-air ducts to the driver may be added to the A-pillar area. They shall be distinctly separate parts from the bodywork. Roof louvers (vents) are allowed for the express purpose of venting the driver's compartment. A maximum of 24 square inches of open area and a maximum number of twelve openings are allowed. Each opening shall be no larger than 4" x ½".
3. The use of any mirror(s) meeting the requirements of GCR Section 9.3.34., is permitted.

d. Interior Modifications - Firewall/Bulkheads

1. Modifications may be made to the driver/passenger compartment for the convenience of the driver and to permit the installation of required safety equipment. Such modifications shall have no influence on the mechanical performance of the car. Similarly, they shall not include the substitution or replacement of any element of the bodywork or chassis except where specifically authorized by these rules.
2. Floor mats, upholstery, and all interior trim shall be removed.
3. There shall be a firewall between the driver/passenger compartment and the engine compartment/ bay. It shall be made of steel and/or aluminum and shall be transversely positioned in the approximate location of the original.
 - A. It shall extend, at minimum, from the left outboard frame rail to the right outboard frame rail, and at maximum from the left outer door skin to the right outer door skin.
 - B. It shall be designed, in conjunction with the floor and driver/passenger compartment interior panels and bulkheads, to prevent the passage of and isolate the driver from flame, fluids, and debris.
4. There shall be a steel and/or aluminum bulkhead completely separating the driver/passenger compartment from the compartment containing the fuel cell.
 - A. The forward most element of this separation shall consist of a vertical transverse bulkhead behind the driver, extending the full width of the compartment from the floor to the top of the door.
 - B. Behind this rear bulkhead there shall be a steel and/or aluminum horizontal bulkhead the full width of the interior of the car or between the inner fenders extending from the vertical bulkhead to the rear of the fuel cell.
 - C. These two bulkheads shall, together, completely cover and isolate the rear suspension, coolers, ducting, etc. so that none of these items are visible when viewed from above. The fuel cell shall also be covered and isolated unless the car is equipped with the optional bulkhead listed below in Paragraph 5.
 - D. All fuel filler, overflow, vent, discriminator, or return lines or components that extend beyond the limits of

the vertical or horizontal bulkheads into the driver/passenger compartment shall be metal, metal braided line, or independently shielded with an additional steel and/or aluminum bulkhead.

5. An additional vertical, transverse bulkhead is permitted behind the driver. It shall be located above the mandatory vertical bulkhead and shall allow the driver adequate vision to the rear. It is recommended that this additional bulkhead be made of a clear, transparent polycarbonate material.

10. Safety (GT-1)

a. Steering Column/Locks

1. The steering column shall be a collapsible type, either by layout design or by column construction, and shall comply with GCR Section 9.3.41, "Steering Wheel Locks."

b. Fuel Cell

1. The maximum fuel cell capacity shall be 120 liters (31.68 gallons U.S.).
2. No part of the fuel cell shall be closer to the ground than six (6) inches, unless contained within *and above the lowest part of* the basic structural frame rails of the vehicle and *fully enclosed*.
3. The fuel cell shall be located in approximately the same location as in the original vehicle, or may be relocated behind the rear axle. It shall not be located within the protected area of the driver/passenger compartment unless specifically authorized in the GTCS.

c. Kill Switch/Battery

1. The battery is unrestricted, provided that it meets the specifications of GCR Section 9.3.9., "Batteries."

d. Brake Lights

1. Two (2) operating brake lights and two (2) operating tail lights are required at the rear of the car.
2. The original tail light and brake light lenses shall be retained, and shall be located in their original positions.

e. Hoses/Lines

1. All fuel, oil, and coolant lines (including those lines that perform fill, overflow, vent, return, etc., functions) which pass through the driver/passenger compartment shall be made of metal or metal braided hose, and shall be equipped with AN-Series threaded couplers.
2. For front engine cars, no oil or fuel line located to the rear of the transverse engine compartment firewall shall be located in a compartment or otherwise restricted area which also contains any component of the exhaust system.

E. APPROVED AUTOMOBILES/NOTES

1. Notes (GT-1)

a. Carburetors/Fuel Injection

1. *Any modular 4bl carburetor may be used with a maximum of a one and eleven-sixteenths (1-11/16) inch throttle bore and 1-1/2" SAE bolt pattern, unless alternate carburetion and/or dimensions are specified in the GTCS.*

9.1.2. Grand Touring Category Specifications

2. Unless otherwise specified or permitted by the GTCS, fuel injection is prohibited on GT-1 automobiles as of January 1, 1994.
3. Pushrod V-6 engines may run a single Holley Model 4500 carburetor, but the minimum weight shall be increased to that of the same displacement fuel injected car.
4. V-8 engine cars with engine displacements of greater than 366 cubic inches (6.0 liters) shall use a one and three-eighths (1-3/8) inch throttle bore restrictor plate, mounted beneath the carburetor, as specified in the diagram.

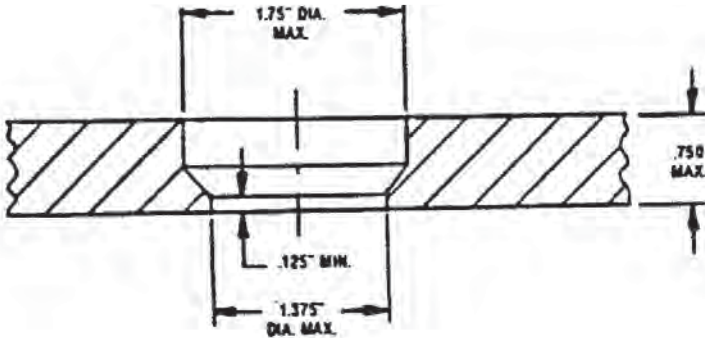

Required Restrictor Plate for GT Engines over 6.0 Liters (366CID).

Throttle Restrictor Plate Material: Aluminum, Thickness 0.75" Maximum.

1.375" Restrictor – Hole must be maintained for a depth of 0.125" Min.

Relief angles to clear Butterflies, Unrestricted.

5. Refer to Sections D.1.b. and c. of these rules for additional induction system specifications.

b. Weight

1. The weight chart is applicable to all cars unless alternate weight(s) is/are specified in the GTCS.

WEIGHT CHART FOR GT-1

Type - cubic inches (liters)	= Carb
V-6 - up to 275 (4.5)	= 2430
V-8 - up to 311 (5.1)	= 2680
V-8 - 312 (5.1) to 335 (5.5)	= 2780
V-8 - 336 (5.5) to 366 (6.0)	= 2880
V-8 - over 366 (6.0) *	= 3180

*With restrictor to 1-3/8" throttle bores per restrictor plate diagram.

Weight in pounds with driver

Note: Ford engines without inline valves (meaning the valves are splayed or canted) shall add 60 lbs.

Note: GM engines using the SB-2 head shall add 60 lbs.

2. All cars using a production based manual transmission having no more than four (4) forward speeds and a working reverse speed may reduce the listed weight by fifty (50)

pounds.

Note: A production based manual transmission is defined as a unit that retains original type gears (i.e., no straight cut, dog ring type gears). It shall be located in the same basic position as used in the production automobile, retaining the standard bellhousing dimensions, and may use any shift linkage.

- All cars competing on ten (10) inch wide rims may reduce the listed weight by fifty (50) pounds.

c. Approved Automobile List (GT-1)	
Make/Model	Wheelbase
American Motors Corporation	
Concord	108.0"
Javelin	109.0"
Spirit	96.0"
Chrysler Corporation	
Chrysler Laser X/T	97.0"
Dodge Daytona	97.0"
Dodge Avenger	106.0"
Dodge Viper GTS	96.2"
Note: Viper shall use a class legal Dodge engine.	
Dodge Viper Competition Coupe	
8.3L sealed engine (4.03" x 3.96"), Comp. ratio: 9.6:1, Trans ratios: 2.66, 1.78, 1.30, 1.00, 0.74, 0.50, Wheelbase: 98.8", Track (F&R): 62.8" / 63.3", Wheels (F&R): 18x11 / 18x13, Tire size (F&R): 305/30 / 335/30, Weight: 3175 lbs. Cars must remain in the original configuration, factory optional equipment is not allowed. May use fuel meeting the requirements for IT cars per the GCR.	
Ford Motor Company - Ford	
<i>Fusion (bodywork)</i>	<i>106.0"</i>
Mustang (1965-68)	108.6"
Mustang (1969-70)	108.0"
Mustang (1979-93)	100.5"
Mustang (1994-1998)	100.5"
Mustang (1999-2004)	100.5"
<i>Mustang (bodywork) (05-08)</i>	<i>102.0"</i>
Roof height 46.5" min. (measured from the ground). Air may be ducted to the carburetor airbox through an opening in the back of the hood, rectangular in shape, maximum width of 20", maximum length 3.5". Opening may extend 1" into the windshield. Approved SCCA Pro Racing bodywork allowed.	
Probe V-6 or V-8	99.0"
Thunderbird (1983-89)	104.0"
Thunderbird (1990-)	105.0"
Taurus (2 door) (98-)	110.0"
Ford Motor Company - Lincoln/Mercury	
Capri (1979-86)	100.5"
General Motors Corporation - Buick	
Regal	108.1"
Somerset	108.1"

9.1.2. Grand Touring Category Specifications

General Motors Corporation - Chevrolet

Beretta 103.4"

Only a beam-type, live-axle rear suspension is permitted.

Camaro (1967-69) * 108.0"

Camaro (1970-81) * 108.0"

Camaro (1982-92) V-6 or V-8* 101.0"

Camaro (1993-) V-6 or V-8* 102.0"

Corvette (1963-67) * 98.0"

Corvette (1968-77) * 98.0"

Corvette (1978-82) * 98.0"

Corvette (1984 -96) V-6 or V-8* 96.2"

Corvette (1997) V-8 104.5"

* Alternate transmissions: THM350 based or THM400 based 3 speed.

Corvette C6 (bodywork only) (05-) ** 102.0"

** *The front undertray and rear fascia and diffuser included in the ACP kit must be replaced with bodywork compliant with the GT1 rules.*

Lumina (1990-) 106.0"

Monte Carlo (95-00) 106.0"

Monte Carlo (01-02) 110.0"

Monza 97.0"

Air may be ducted to the carburetor airbox through an opening in the back of the hood, rectangular in shape, maximum width of 20", maximum length 3.5". Opening may extend 1" into the windshield. Approved SCCA Pro Racing bodywork allowed.

LS1 V8 engine allowed with stock plastic intake manifold @ 2680 lbs.

General Motors Corporation - Oldsmobile

Cutlass Ciera (1987-) 105.0"

Cutlass (1988-) 104.0"

Toronado (1987-) 105.0"

Aurora (2dr.) 106.0"

Air may be ducted to the carburetor airbox through an opening in the back of the hood, rectangular in shape, maximum width of 20", maximum length 3.5". Opening may extend 1" into the windshield. Approved SCCA Pro Racing bodywork allowed.

General Motors Corporation - Pontiac

Fiero 94.0"

3300cc (4-cyl.), multi-carb and fuel injected weight = 1830 lbs.

3100cc (GM V-6) multi-carb and fuel injected weight = 1830 lbs.

4500cc Chevrolet 90 deg V-6 weight = 2430 lbs.

V-6 engine may be repositioned longitudinally in the engine bay along vehicle centerline. GM V-6 bow tie block #10051141 may be used.

Mid engine configuration – may place fuel cell within the protected area of the driver/passenger compartment provided that it meets all constraints of GCR section 9.3.26.

Transverse V-6 may deduct fifty (50) lbs.

Firebird/Trans-Am (1969)* 108.0"

Firebird/Trans-Am (1970-81)* 108.0"

Firebird/Trans-Am (1982-1992) * 101.0"

Firebird/Trans-Am (1993-)* 102.0"

Grand Prix 106.0"

* Alternate transmissions: THM350 based or THM400 based 3 speed. Air may be ducted to the carburetor airbox through an opening in the back of the hood, rectangular in shape, maximum width of 20", maximum length 3.5". Opening may extend 1" into the windshield. Approved SCCA Pro Racing bodywork allowed.

LS1 V8 engine allowed with stock plastic intake manifold @ 2680 lbs.

Jaguar

XK8 / XKR 100.5"
 Note: shall use a class legal Ford engine.

Mazda

RX-7 95.2"/95.7"
 RX-8 102"
 12A engine, multi-carb or fuel inj. weight = 1780 lbs.
 13B engine, multi carb or fuel inj. weight = 1770 lbs.
 20B engine, multi carb or fuel inj. weight = 2100lbs.

Nissan

300ZX/Z31 101.2"
 3000cc V-6 engine, multi-carbs weight = 1880 lbs.
 300ZX/Z32 (1990-) 101.2"
 VG30D V-6 engine, (3) 48mm IDF with 40mm venturis weight = 1930 lbs. Permitted alternate hood: P/N 99996-Z32HP

Porsche

911 89.4"
 3800cc 6, multi-carb or fuel injection weight, twin-plug head, dual ignition distributor weight = 1880 lbs. Factory spoiler P/N 930-512-023-00 & 930-512-021-00 (or kit# 930-512-901-01). Entire assembly only (with rubber lip). No alternate materials, no reproductions.

911 Cup 3.8 RSR
 with the following additional specifications: Wheels: (F) 18 x 12, (R) 18 x 13, Allow FIA GT-2 front bumper cover, Allow FIA GT-2 "banana" rear spoiler, Transmission: 6 speed, Type G50/30, Weight: 2310 lbs (w / driver). Original, factory-installed Matter roll cage structures permitted. May use fuel per the IT specs of GCR section 9.3.25.

Boxster 89.4"
 alternate engine: 3.8 liter air-cooled, multi-carb or fuel injection, twin-plug head, dual ignition distributor. weight = 1880lbs. Shall have windshield and hardtop installed by 1/1/2003.

GT3 R/RS (00-02)
 3600cc, Wheels: (F) 18 x 10", (R) 18 x 11", Allow FIA GT-2 front bumper cover, Allow FIA GT-2 "banana" rear spoiler, Transmission: 6 speed Type G50/30, Original, factory-installed Matter roll cage structures permitted, weight 2425lbs. May use fuel per the IT specs of GCR section 9.3.25.

997 GT3 Cup
 Shall run as delivered for the GT3 Cup Challenge except that tires are unrestricted and fuel per IT specs. Cars shall meet the safety requirements as specified in the GCR except that original, factory installed roll cage is permitted. Competitors shall have a copy of the Cup Challenge rules in their possession. Minimum weight 2810 lbs w/ driver.

Panoz

Esperanté 106.0"
 Note: Shall use a class legal Ford engine.

Shelby

Cobra 90.0"

F. GT-2, 3, LITE PREPARATION RULES

F.1. GT Cars registered as GT cars prior to January 1, 1990.

All GT cars registered as GT cars prior to January 1, 1990 shall use the manufacturer's original engine location, i.e., front, mid, rear; drive location, i.e., front or rear, and type of front and rear suspension, i.e., MacPherson strut, double A-arm, live axle, semi trailing arm, etc., unless authorized by the GTCS for a specific make and model.

Front-engined GT cars registered as GT cars prior to January 1, 1990 may be converted to Section F.2., specifications, but shall meet ALL specifications of Section F.2.

F.2. GT cars registered as GT cars after January 1, 1990.

All front engined GT cars registered as GT cars after January 1, 1990 shall utilize McPherson strut or double A-arm front suspension. A-arm front suspensions shall have the shocks attached to the outboard end of an upper or lower control arm. Rocker arms, push-pull rods, etc., are prohibited. Front wheel drive cars may convert to rear wheel drive. Cars classified in GT2-Lite that retain the original front wheel drive (FWD) configuration may retain the original type of rear suspension with no weight penalty or use a beam axle.

Cars classified in GT2-Lite running front engine, rear wheel drive (RWD) may use independent rear suspension (IRS), by choice at a weight increase equal to 2.5% of the car's specified weight.

All 1990 model year and later rear and mid-engined GT cars may use the manufacturer's original type of suspension or double A-arm front and rear independent suspension as defined above. All rear and mid-engined GT cars manufactured prior to the 1990 model year shall retain the manufacturer's original type of front and rear suspension.

All GT cars registered as GT cars after January 1, 1990 or updated to Section F.2.. specifications shall utilize left side driver placement.

F.3. Safety Equipment required on all cars.

a. Bulkheads

1. A metal bulkhead shall separate the driver/front passenger compartment from the compartment containing the fuel cell. The fuel cell, cap, filler neck, and all fittings shall be isolated so that in case of spillage, leakage, or failure, fuel will not reach the driver. The bulkhead separating the driver/passenger compartment from the fuel cell shall not be above the bottom of the rear window and the bottom of the side/quarter windows. An additional vertical, transverse bulkhead is permitted behind the driver. It shall be located above the mandatory vertical bulkhead and shall allow the driver adequate vision to the rear. It is recommended that this additional bulkhead be made of a clear, transparent polycarbonate material.

b. Fuel Cells

A safety fuel cell complying with GCR Section 9.3.26., shall be installed. All fuel cell vents shall incorporate check valves to prevent fuel spillage. Dry-break refueling couplings and discriminator valves may be installed, provided they do not extend beyond the bodywork.

c. Windows

1. Windshield safety clips and rear window safety straps shall be installed on all closed cars. Three (3) clips (3 inch x 1 inch x 1/8 inch) shall be bolted or riveted to the body at the top of the windshield. Two (2) clips (3 inch x 1 inch x 1/8 inch) shall be

bolted or riveted to the cowl and extend over the bottom edge of the windshield. Clips shall be spaced a minimum of twelve (12) inches apart. The rear window shall be secured with two (2) metal straps (1 inch wide x 1/8 inch thick) bolted or riveted to the body at the top and bottom of the rear window. Polycarbonate windshields such as Lexan are allowed. Alternate windshields must be of 6mm minimum thickness. Alternate material windshields must be identical in size and curvature to the original glass component. Alternate material windshields must have in addition, three (3) inner supports to prevent the windshield from collapsing inward. These supports must be 0.75" by .125" minimum straps of aluminum. Spacing between these inner supports must be six (6) inches minimum.

3. Windshield - Open Cars: The windshield and all side and rear glass on open cars shall be completely removed, including all mounting brackets and fixtures, and a suitable windscreen installed.

Said windscreen shall be made of a transparent material and shall not exceed the height or width of the original windshield/screen. The replacement windscreen shall be fitted within the vertical planes of the frontmost and rearmost elements of the original windshield/screen.

4. Ducts may be installed in the side windows or window openings for the purpose of supplying cooling air to the driver and/or differential/transmission coolers and/or the rear brakes. Air passing through the differential/transmission coolers may be exhausted through an opening identical in size and location to the rear license plate frame.

F.4. Authorized Modifications

The following modifications are authorized on all GT-2, 3, and Lite cars. Modifications shall not be made unless specifically authorized herein. No permitted component/modification shall additionally perform a prohibited function.

a. General

1. It is not permitted to make any changes, alterations, or modifications to any component produced by the manufacturer, unless specifically authorized by these rules, or required by the GCR.
2. Any springs (including torsion bars) may be replaced by others of unrestricted origin, unless specifically prohibited by these rules.
3. Where alternate suspension and/or drive train equipment is authorized, modifications to the car/chassis are permitted to install authorized equipment, provided the modifications serve no other purpose.
4. All component parts of the bodywork, such as hood, doors, fenders, deck lid, rocker panels, windshield surround, roof, etc., may be lightened or replaced by ones of alternate materials, provided the shape, size, and relative position is identical to the original or approved alternate. The original size, angle, and relative position of the windshield shall be maintained. Convertible tops, sunroofs, and removable panels shall meet GCR Section 9.3.17.

Vents may be added to the roof panel or rear window for

9.1.2. Grand Touring Category Specifications

the express purpose of venting the driver's compartment. A maximum of 24 square inches of open area and a maximum number of twelve openings are allowed. Each opening shall be no larger than 4" x ½".

5. Spare wheel and tire shall be removed.
6. Glass and/or plastic headlights, front parking lights, front signal lights, lenses, and bulbs shall be removed. Headlight openings shall be covered with a wire mesh screen or panel having the same contour as the original lens, mounted so that the headlight bezel/rim remains in place, maintaining the standard appearance of the Production automobile. Side marker light assemblies shall be removed and the resulting openings covered with a plate whose dimensions do not exceed those of the original parts; side marker lights that are an integral part of the taillight assembly cannot be removed. Other lighting parts and operating mechanisms may be removed. In the case of pop-up headlights, the entire assembly may be removed and the opening covered with a screen or plate (as above, without the headlight bezel/rim requirement) which provides a stock appearance. It is not permitted to relocate the standard headlight, parking light, signal light, etc., openings. Taillights shall be in the original location and shall be the original style/type of taillight for the make, model, and year of car.

Ducts from headlights, front parking lights, and front signal lights in the front of the car may be used for ducting air to the engine, front brakes, and/or oil cooler(s). These ducts may pass through interior panels for this purpose. The cross section area of a single duct shall not exceed the cross sectional area of the original (single) headlight.

b. Chassis and Bodywork

The purpose of the following rules is to maintain recognizable external features of the manufacturer's make and model, while providing necessary safety and performance modifications.

Restrictions regarding external body shape and use of belly pans are aimed at preventing attempts to obtain ground effect or streamlining. Provisions in the rules permit one-off chassis and frames, to reduce the cost of building and repairing GT cars, not to permit high technology (streamlining and/or ground effects). Semi-monocoque or monocoque construction is prohibited.

1. The external shape of the body cannot be changed, except when specifically authorized. Standard grills, window openings, or approved facsimiles shall be retained. All external trim and model identification may be removed. Misalignment or modifications to create ventilation where none previously existed are prohibited. One piece front and one piece rear bodywork is allowed. Rocker panels and doors may be parted and/or integrated with associated body panels. Rocker panels of an alternate material may be a flat vertical panel having the same dimensions as the original component when viewed from the side. Overall width of the vehicle/rocker panel measured at the door sill must remain stock. Roof/A-pillars shall be separate pieces. The cowl trim panel may be modified or removed.
2. Chassis, frame, or subframe may be lightened, reinforced, or replaced, provided components and attachments are not relocated, except where specifically permitted. Reinforcing does not authorize the use of belly pans forward of the firewall,

or aft of the front edge of the rear wheel opening. The floor behind the rear wheel opening shall be flat and follow, but not exceed, the line of the rear fender bottom. Only the fuel cell container may protrude or extend below this plane.

3. No part of the bodywork or chassis, to the rear of the front wheel opening, shall touch the ground when both tires on the same side of the car are deflated.
4. The firewall and floor may be replaced with aluminum alloy or steel. Firewalls may be modified or notched.
5. Bumpers may be removed providing all projecting hardware is removed except when it (they) are an integral part of the bodywork, in which case it (they) may be replaced with replica(s) of different material. Non-integral bumpers may be replaced with a replica of alternate material or removed. Bumper bracket holes in the bodywork may be covered provided such covering serves no other purpose.
6. All standard production seats and seat backs shall be removed. The driver's seat shall be replaced with a one-piece bucket-type race seat. Such seat shall be installed so that a second seat of the same dimensions could be simultaneously fitted to the passenger's side of the car (no center seating).
7. Doors shall be pinned or otherwise positively fastened to prevent their opening in case of an accident. Standard door hinges and latch mechanisms may be removed, but the doors shall be capable of being opened or removed unless integrated into the bodywork. Interior door panels may be removed and the door window slots may be covered. Pins or straps may be added to hood and deck lid to supplement or replace the latches. Hood and deck lid hinges may be removed.
8. All driver and front passenger door window glass shall be removed. Window cranks and mechanisms may be removed. Rear quarter, rear side, and rear windows may be of transparent (clear) polycarbonate material, minimum thickness 3mm, but shall remain in the same position in the frame or opening as the original glass it replaces; rubber molding optional. Rear windows/hatchbacks and deck lids shall be completely closed. No bumper blocks or other means of poor alignment of bodywork will be permitted. Rear quarter (side) windows may be run in their original open or closed position.
9. Fenders may be flared for tire clearance, provided their shape and opening contour, in the horizontal projection, is similar and proportional to the original opening. Rear doors on 4-door automobiles may be considered part of the fender for purposes of fender flaring. The tire shall not extend beyond the fender openings at the highest point of the tire. The rear fender flares on GT-2 cars may extend forward into the door, no more than 26 inches from the rear axle centerline (GT-2 only). Wheel opening location may be altered in accordance with the allowable wheelbase tolerance in order to maintain vehicle's stock appearance. Ventilation openings, other than those which are standard production on the recognized model, are prohibited.
10. Front and rear inner fender panels may be altered, replaced, or removed provided there are panels providing total separation between driver compartment and wheel wells.

9.1.2. Grand Touring Category Specifications

11. Replacement, addition, or removal of accessories (gauges, switches, indicators, etc.), or other interior modifications for driver convenience, or to permit installation of required safety equipment, is authorized provided such modifications have no influence whatever on the mechanical performance of the car. Such modifications do not include the substitution or replacement of any bodywork or chassis component except those specifically authorized by these rules. Floor mats and all interior trim shall be removed.
12. A spoiler may be fitted to the front of the car. It shall not protrude beyond the overall outline of the car as viewed from above except as follows:

GT2: a front splitter may extend up to three (3) inches.

GT3: a front splitter may extend up to two (2) inches.

In all classes, the spoiler shall not extend aft of the forward most part of the front fender opening (cutout), and shall not be mounted more than four (4) inches above the horizontal centerline of the front wheel hubs. The spoiler shall not cover the normal grill opening at the front of the car. An intermediate mounting device may be used on cars whose front bodywork is above the four (4) inch minimum. Openings are permitted for the purpose of ducting air to the brakes, radiator, airbox and/or oil cooler(s); equal openings may be placed in the standard lower front panel directly behind openings placed in the spoiler. When bumpers are retained, the spoiler and bumper shall appear to be two separate parts. The spoiler "pan" area forward of the leading edge of the front wheel openings shall be flat and follow, but not exceed, the line of the front fender/spoiler bottom. No components may protrude or extend below this plane.

13. A spoiler or a Club Racing specified rear wing for GT2 and GT3 may be fitted to the rear of the car. *Note: OEM rear spoilers and wings are not permitted unless specifically listed on the vehicle's specification line. If a spoiler is used, it shall be contiguous with the bodywork and shall comply with the following:*
 - A. Height (max): six (6.0) inches (GT-2 & 3) or five (5.0) inches (GT-Lite) measured from the bodywork along the face of the spoiler from the point of attachment to the top of the spoiler. In the case of a spoiler with a curved top edge conforming to the shape of the bodywork (rear-view), the measurement is to be made perpendicular to the tangent of the body at the point of attachment. In the case of a spoiler mounted with a vertical mounting flange on the bodywork, the measurement shall be made ignoring any slight amount of mounting flanges (see below) exposed due to the curvature of the rear bodywork at the point of attachment.
 - B. Width and Overhang: If roof mounted, no wider than the roof at its mounting point when viewed from above the car. Mounting to be no further rearward than the forward most part of the rear window. If rear mounted, no wider than the body, excluding fender flares, from the forward most part of the spoiler (or mounting flange) rearward. Shall not extend rearwards of the rearmost extremity of the bodywork for the entire width of the car (when viewed

vertically from above the car at any point, the spoiler shall not protrude beyond the bodywork).

- C. Mounting: Spoilers shall be strong enough to be self-supporting. A mounting flange no greater than one and one-half (1-1/2) inches wide, contiguous with the bodywork, (either forward facing on the top surface of the bodywork or downward facing on the rear surface of the bodywork) shall be employed. Supplemental forward bracing may be added in the form of two (2) rods, mounted at least ten (10) inches inboard from the ends of the spoiler. Rear supports may be added.
- D. Configuration: The spoiler shall be a single plane spoiler (a straight line in any vertical cross section) uniform in height from the bodywork with no more than 1/8" gaps/openings below the spoiler to facilitate imperfect mounting. The gaps/ openings are to be included in the overall height of the spoiler. Only enough curvature (in a fore and aft direction as viewed from above) shall be permitted to facilitate mounting. The use of fences, end rails, Gurney flaps, wickerbills, or other forward facing lips or aerodynamic devices is prohibited.

NOTE: O.E.M. rear spoilers are not permitted unless specifically listed on the vehicle's specification form.

If a Club Racing specified wing is used (GT2 and GT3 only), it shall comply with the following:

- E. *A single element, single plane airfoil scaled to a chord length of 10.75 inches.*
- *In GT2 only, a maximum 0.50 inch Gurney tab is allowed at the trailing edge of the wing element. The tab must be mounted 90 degrees to the upper wing surface. No air may pass between the tab and the wing.*
 - *The wing end plates must fit within a rectangle measuring 11.00 inches long by 4.00 inches tall. No portion of the wing element or tab may extend beyond the perimeter of the endplate. The endplates must be mounted parallel to the vehicle centerline, and must be perpendicular to the ground. Endplates must be flat, with no curvature or Gurney tabs.*
 - *GT2: The maximum width of the entire wing assembly (wing element, endplates, Gurney tab, and mounting hardware) is 68.00 inches, but no wider than the rear body width including fender flares.*
 - *GT3: The maximum width of the entire wing assembly (wing element, endplates, and mounting hardware) is 64.00 inches but no wider than the rear body width including fender flares.*
- F. *Wing mounting*
- *GT2: The entire wing assembly must be mounted below the highest point of the roof or roll cage main hoop whichever is higher measured at the highest point.*
 - *GT3: The entire wing assembly must be mounted at least 4.00 inches below the highest point of the roof or roll cage main hoop whichever is higher measured at the highest*

point.

- *GT2 and GT3: The trailing edge of the wing assembly must be located within an area defined by a point; 6" forward of rearmost bodywork and the rearmost bodywork measured at vehicle centerline.*
 - *Two wing mounting posts must be used, with each one located between 8"-20" inboard from end of wing. The exposed portion of the wing mounting posts shall not exceed 85 square inches each. Curved brackets will be measured as if they're in a flat plane as viewed from the side. Mounting brackets are to be included in measurement.*
 - *The maximum wing angle from horizontal is 30-degrees.*
14. *GLite rear wing: The maximum width of the entire single element, flat plane wing assembly is 56.0 inches wide x 8.0 inches chord depth, but no wider than the body width including fender flairs. Wing endplates must fit within a rectangle measuring 8.5 inches long by 3.00 inches tall. Endplates must be flat with no curvature or Gurney tabs. A maximum 1/2 inch wicker-bill may be employed. The wing must be mounted to trunk/deck lid with two (2) mounting brackets. Each mounting bracket must attach to the wing at a point that is at least 2 inches inboard of the endplates. The internal parts of the brackets may protrude through the trunk/deck lid to allow for the two parts of each bracket to be fastened together. The rear wing must be mounted a minimum of 6.0 inches below the peak of the roof. Cars with a wagon-back style body (e.g., Civic, Fiesta, Mini, etc.) may have the wing mounted at the trailing edge of the roof, a maximum of 4.0 inches above the roofline. The mounting position will be measured between the highest points of the roof and wing. In either application, the trailing edge of the wing assembly must be located within an area defined by a point, 6 inches forward of rearmost bodywork and the rearmost bodywork measured at vehicle centerline.*
15. *GLite front splitter: A front splitter may be added that is a flat single-plane, with an exposed top surface not more than 2.00 inches. The splitter shall be mounted flat. The splitter must not extend laterally any further than the widest point of the front fenders. The splitter must have no vertical deviations. Additionally, a maximum of four (4) rods or cables may be used to support the front, and/or the sides of the splitter. A single-plane vertical close-out panel may be used to bridge any gaps between the front fascia and splitter.*

c. Suspension and Wheels

1. Wheelbase will be homologated on a case by case basis as requested by the manufacturer. Wheelbase may be changed from -3" to +1" from printed stock dimensions in a fore/aft direction.
2. Suspension components may be reinforced, modified, or replaced as long as the type of suspension is not changed from that authorized in this GTCS.
3. Suspension mounting points, including suspension springs, may be relocated.

4. Suspension springs may be replaced with others of unrestricted origin.
 5. Modifications or substitution of hubs, bearing, spindles, axle shafts, universal B joints, flex joints, and CV joints is permitted.
 6. Addition or substitution of antiroll bars, camber compensating devices, and/or suspension stabilizers is permitted. If these devices extend into the driver/passenger compartment, they shall be completely sealed off by metal panels.
 7. Suspension bushings and joints may be replaced by others of different material and/or design. Offset bushings and spherical bearings are permitted, including adjustable type.
 8. Steering arms, pitman arms, and steering linkage component parts may be modified, reinforced, or substituted. The steering system may be changed and/or relocated.
 9. The steering wheel may be replaced and rake of the steering column may be altered. A collapsible type of steering column equivalent to Federal Motor Vehicle Safety Standard No. 204 is required in all cars registered after January 1, 1983 and highly recommended for prior registered cars. GT cars registered after January 1, 1990 or GT cars converted to Section F.2., specifications shall have left side driver placement.
 10. Substitute wheels of any type may be used. All four (4) wheels shall be of the same diameter except in GT2. GT2 cars may run any tire/wheel combination provided that the tire does not exceed a maximum cross section width of 12.0" in the front and 13.75" in the rear. *GT2 cars using 15 x 7" wheels exclusively may reduce the listed weight by 50 lbs.* The maximum wheel size for GT3 cars is 15 x 7" and for GTL cars is 13 x 7" unless alternates are listed on the vehicle specification line. Alternatively, any wheel up to 15 x 7" may be used in GTL with a weight penalty equal to four percent of the car's weight as listed on the spec line. The minimum vehicle weight shall be rounded to the nearest pound.
 11. Shock absorbers: It is not permitted to alter the number of shock absorbers. The make of shock absorber and its points of attachment may be moved. Shock absorbers may have load bearing capacity; e.g., gas filled or coil over. When using load bearing shocks, the original springs may be removed. GT cars registered after January 1, 1990 or GT cars converted to Section F.2., specifications shall have the shock absorber attached to the outboard end of an upper or lower control arm. Rocker arms, push-pull rods, etc., are prohibited.
- d. Electrical Systems**
1. Standard battery may be replaced by one of different make and capacity. The battery may be relocated and shall be securely mounted and enclosed in a non-conductive protective box.
 2. The electrical/electronic system may be modified or replaced provided an operating starter motor and two (2) brake lights are retained.
 3. Any distributor or transistorized ignition system (including crank triggered), firing the same number of spark plugs as the original distributor, may be used.

9.1.2. Grand Touring Category Specifications

4. Magneto ignition is prohibited unless listed in the GTCS. Ignition wiring and spark plugs are unrestricted.

e. Engine and Drive Train/General

1. Exhaust manifold(s), header(s), tailpipe(s), and muffler(s) may be of unrestricted origin. The exhaust pipe(s) and/or muffler(s) may be recessed into the floor panel and rocker panel. The exhaust may be recessed into the bottom of the door or rear fender below a line seven (7) inches above the bottom of the rocker. There may be a maximum of two (2) such areas in the door or fender, with the maximum length for each no more than seven (7) inches. Note that the exhaust outlet shall still be mounted as low as possible; this does not authorize exhaust outlets through the door. Exhaust opening(s) shall exit to the rear of the wheelbase centerline and away from the body.

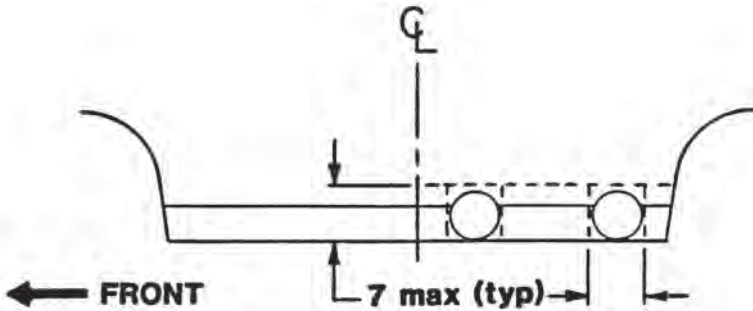

180 degree headers: The passenger's side floor pan may be raised not more than ten (10) inches to accommodate the installation of the exhaust system and muffler(s) provided such raising of the floor serves no other purpose. Exhaust may pass through the rear bodywork no higher than the rear axle centerline.

2. Exhaust emission control air pumps, associated lines and nozzles, and EGR devices cannot be modified in any way except that they may be completely removed. When air nozzles are removed from the cylinder head, the holes shall be completely plugged.
3. Substitution or modification of the clutch and/or flywheel is permitted.
4. It is permitted to lighten, balance, or modify in shape, by tooling, the standard or optional components of the engine and drive train, provided it is always possible to identify them as such. Material shall not be added to these components unless specifically authorized by these rules.
5. Alternate engine and drive train components considered replacement parts, such as seals, bearings, valve guides, pushrods, water pump, timing chains/belts and sprockets, nuts, bolts, studs, washers, and gaskets are permitted. Bushings or offset keys of unrestricted origin may be installed.
6. The substitution of valve spring retainers and keepers is permitted. Valve springs are unrestricted (including number) provided the type and location remain unchanged.
7. Generator (alternator), crankshaft, and water pump pulleys may be altered or replaced with others of unrestricted origin.

Any crankshaft vibration dampener is allowed.

8. Any oil pan (sump), oil pump(s), and/or pickups are allowed. Oil pump(s) shall be driven mechanically by the engine. Dry sump systems are permitted. The oil tank shall be located within the bodywork. The oil tank, cap, and all fittings shall be isolated so that in case of spillage, leakage, or failure, oil will not reach the driver. Any oil filter(s) may be used.
9. Installation of any vent or breather on the engine, transmission, or differential is permitted (See "Oil Catch Tanks"). Crankcase vacuum devices are prohibited.
10. *Any readily available manual transmission having no more than six (6) forward speeds in GT2 and five (5) forward speeds in GT3 and Lite and a functional reverse speed may be used, provided that it is fitted in the same basic location used in the standard production automobile.* Any shift linkage may be used. If a sequential shift gearbox is used, the car must carry a weight penalty equal to 1.25 percent of the weight as listed on the spec line. If a synchromesh engagement transmission is used, the weight may be reduced by 1.25 percent of the weight listed on the spec line. A synchromesh gearbox is one having a friction mechanism to allow engagement. Note: The minimum vehicle weight is to be rounded to the nearest pound. Air, hydraulic or electric actuation of the gearshift mechanism is not allowed. For front engine, rear drive cars requiring the transmission to be attached to the engine, the transmission front seal shall be within twelve (12) inches of the back of the engine block. On front engine/rear drive cars, the transmission front seal is that seal which is within 5" of the gear on the input shaft which meshes with the foremost gear on the counter/layshaft.

A functional reverse is defined as "operable by the driver from his normal seated position and capable of sustained movement of the vehicle, under its own power, in a reverse direction." A driver-operated device for locking out reverse gear may be added provided it does not prevent prompt engagement of reverse in an emergency situation.

11. Heavy duty propeller shaft(s) and/or drive shaft(s) may be used. Steel retaining strap(s) shall be used to prevent drive shaft failure from dropping or entering driver compartment.
12. Any axle tube, final drive housing, gear ratio, limited slip, or locked differential may be used. Final drive units which permit ratio changes while the car is in motion are prohibited. GT cars registered after January 1, 1990 or GT cars converted to Section F.2., specifications, using the front engine/rear drive configuration, shall use a "closed tube" rear axle housing.
13. Engine and transmission mounts may be of alternate shape and/or material. Cars with engines mounted longitudinal to the chassis MAY relocate the engine in a longitudinal, not lateral, direction within the following restrictions: (Note: A tolerance of up to a 1.0 inch setback is allowed if the engine is relocated.)
 - A. V8, V6, and V4 engines shall align the center of the foremost spark plug hole in line with the front axle spindles.
 - B. In-line six (6) cylinder engines shall align the center of the

9.1.2. Grand Touring Category Specifications

- first spark plug hole (from the front) in line with the front axle spindles.
- C. In-line four (4) cylinder engines shall align the center of the first spark plug hole (from the front) in line with the front axle spindles.
 - D. Rotary engines shall align the forward most spark plug hole in line with front axle spindles.
 - E. The engine may be rotated about the crankshaft centerline (lean over) a maximum of fifteen (15) degrees unless otherwise noted and shall not cause hood bulges.
14. Any transverse mounted engine may be rotated for axle/CV joint alignment. Any readily available transmission having a functional reverse and no more than five (5) forward speeds may be used, provided it is mounted to the rear of the engine. All transverse engines may be rotated 180 degrees. A transverse mounted engine may be rotated to a longitudinal position that places the crankshaft centerline on the longitudinal centerline of the car (shall conform to all restrictions in Section 9.1.2.F.4.e). The engine may be rotated about the crankshaft (lean over) a maximum of fifteen (15) degrees unless otherwise noted and shall not cause hood bulges. Rear axle / suspension per GTCS 9.1.2.F.2.
- f. Engine, Reciprocating**
- 1. Engines may be rebored a maximum of 1.2mm (0.047 inch) over the standard bore size listed in the GTCS. A cylinder block from any model from the same manufacturer which is of the same material and dimensionally identical throughout, except for non-critical bosses, is permitted.
 - 2. Crankshaft main bearing caps may be modified or substituted. Main bearing cap straps or girdles and/or additional main bearing cap bolts may be used, provided that no material is added to the block for their attachment.
 - 3. The crankshaft may be replaced with another of the same basic material, but with no change in stroke and provided the angles of the crank throws remain the same. The engine firing order shall remain unchanged.
 - 4. Connecting rods may be replaced with any connecting rod of steel (ferrous) material. Aluminum, titanium, and non-metal connecting rods are prohibited, except where fitted as standard.
 - 5. Any pistons and piston pins may be used.
 - 6. Any camshaft(s) may be used, provided locations are (is) the same as standard.
 - 7. Any cam followers may be used, except that roller cam followers shall not be used unless fitted as standard equipment.
 - 8. Any rocker arms and rocker assembly supports may be used.
 - 9. Valve sizes are unrestricted except when limited by the GTCS for specific automobiles. Centerlines shall not be altered. Valves may be of alternate material; non-metal is prohibited.
 - 10. Compression ratio may be altered by machining, using any

head gasket(s) or elimination of head gasket(s).

g. Engine, Rotary Piston

1. The capacity of the working chamber(s) shall not be changed.
2. The eccentric shaft may be replaced with another of the same basic material, but no changes in eccentricity or journal dimensions are permitted.
3. Rotor is unrestricted, providing the material and number of lobes remain unchanged.
4. Alternate rotor housings are allowed only as listed in the GTCS for specific automobiles. No changes are allowed in the epitrochoidal curve in alternate housing.

h. Cooling Systems

1. Cooling fan(s) may be modified, substituted, or removed. Electrically operated cooling fan(s) may be installed, provided it (they) serve no other purpose. The use of any engine, transmission, and/or differential oil coolers(s) is (are) permitted provided it (they) are mounted completely within or under the bodywork, but not in the driver/passenger compartment. Associated oil cooler pumps and lines are permitted for the transmission and differential. Air ducts may be fitted to the oil cooler(s) as specifically authorized herein.
2. Any water radiator is allowed, provided there are no changes in the exterior bodywork to accommodate its use. It shall not be located in the driver/ passenger compartment. Separate expansion or header tank(s) are permitted, provided they are mounted in the engine compartment. The heater core may be removed entirely but not modified or replaced.
3. Sealing or shrouding the airflow area between the normal grill opening and the water radiator is permitted.
4. On water cooled cars, thermostats may be modified or replaced with blanking sleeves or restrictors.
5. Alternate fan and fan shroud are permitted on air cooled engines.

i. Fuel Induction System

All inducted air shall pass through venturi(s), maximum one (1) per cylinder or rotor.

1. Any air filter(s) may be used, or the filter(s) may be removed. Velocity stack(s) and/or air box(es) may be fitted. Air may be ducted to the carburetor(s) provided the ducting is contained within the engine compartment and air is supplied through normal openings in the bodywork (or as specifically authorized herein).
2. Any fuel pump(s) may be used and the location(s) may be changed. Fuel pump(s) shall not be located in the driver/passenger compartment.
3. All fuel/oil lines passing through the driver/passenger compartment shall be steel or metal braided hose. Number of fuel lines is unrestricted.
4. Carburetors:
 - A. Reciprocating engines: Carburetor(s) and intake manifold(s) are unrestricted except as limited in the GTCS for a specific

9.1.2. Grand Touring Category Specifications

make/ model. All cars with restricted carburetion are required to use I.R. manifolds with no plenums or balance pipes unless using an SIR or otherwise restricted for specific automobiles. Intake manifold(s) shall be attached to the head(s) without modification to the head(s).

- B. Rotary engines: Carburetor and intake manifold are unrestricted except as limited in the GTCS for a specific make/ model. All cars with restricted carburetion are required to use I.R. manifolds with no plenums or balance pipes, unless using an SIR. Intake manifold(s) shall be attached to the end cover(s) or rotor housing(s) without modification to the end cover(s) or rotor housing(s).
 - C. No portion of the intake manifold(s) may extend into the intake ports (reciprocating and rotary engines.)
 - D. Carburetors shall incorporate a butterfly-type throttle plate for engine speed control.
 - E. Where Weber or Weber-type carburetors are specified and used, they shall retain their standard configurations of fuel distribution. This is to prohibit annular discharge carburetors.
 - F. Where Weber carburetors are specified, Weber-type carburetors may be substituted. The following are approved Weber-type carburetors: Weber, Solex, SK, Mikuni, Delorto, Berg, and PMO.
5. Any car may utilize fuel injection, whether originally equipped with fuel injection or not. The following restrictions apply.
- A. Both method and manufacturer are open.
 - B. Intake manifold shall be of the individual runner type, unless using an SIR or otherwise notes on the vehicle spec line. Cars using an SIR may use any manifold type.
 - C. Only butterfly-type throttle control, one per cylinder or rotor, is permitted unless using an SIR. Cars using an SIR may use any butterfly-type throttle control. If intake restrictors are specified on the vehicle specification line, the restrictors shall be round orifices (unless otherwise specified) and located within four (4) inches of the throttle butterfly. SIR location is unrestricted so long as all SIR criteria are met. Restrictors shall be a minimum .060" thickness and of the specified diameter.
 - D. All inducted air for each cylinder must pass through the specified restrictor. Fuel injected cars, unless otherwise specified, shall use the same individual venturi restriction size specified for a car using carbureted induction.
 - E. The number of injectors shall be one (1) per cylinder (unless otherwise noted on the vehicle specification line).
 - F. Rotary engines may use two (2) injectors per rotor.
6. Supercharging/turbocharging is prohibited.
7. Float(s) shall not be removed or altered to produce (a) floatless carburetor(s).
8. Any throttle linkage may be used.

9. Induction systems shall be equipped with a positive method of throttle closing by means of (an) external spring(s).

j. Brakes

1. Any dual master cylinders and/or pressure equalizing/regulating device(s) are permitted.
2. Servo-assist systems are unrestricted.
3. Backing plates/dirt shields may be ventilated or removed. Brake air ducts may be fitted within the provisions of these rules.
4. The hand brake may be removed.
5. Brake lines shall be steel or metal braided hose. They may be relocated and may be given additional protection.
6. Brake calipers and/or drums are unrestricted except as limited by the GTCS for a specific make/model. Brake rotors shall be ferrous material but are otherwise unrestricted. Brake rotors/drums shall be located in the original position (e.g., inboard vs. outboard).
7. Water cooled brakes are permitted, maximum reservoir capacity two (2) gallons, maximum line size 3/16 inch I.D. The water shall be atomized by an atomizing nozzle, and the water shall enter the air duct a minimum of twelve (12) inches from the centerline of the spindle/axle.

GT2 Cars - ACURA

Model	Years	Body Style	Drive-line	Wheel-base (in)	Notes
NSX	NA	2dr	RWD	99.6	The fuel cell(s) may be relocated to the front trunk area.
RSX	NA	2dr	FWD	101.2	No mid-engine mounting. Hood bulge permitted with no openings.

Engines - ACURA

Engine Family	Engine Type	Bore x Stroke (mm)	Disp. (cc)	Head Type	Valves/ Cyl.	Fuel Induction	Weight (lbs)	Notes
	DOHC	87.0 x 84.0	1997	Alum, Crossflow	4	Automotive type sidedraft	1950	
	DOHC	87.0 x 90.7	2157	Alum, Crossflow	4	Automotive type sidedraft	1950	
	DOHC	89.9 x 78.0	2971	Alum, Crossflow	4	Automotive type sidedraft	2280	
	DOHC	93.0 x 78.0	3176	Alum, Crossflow	4	Automotive type w/ 40mm choke(s)	2330	
	SOHC	89.0 x 86.0	3210	Alum, Crossflow	4	37mm SIR	2280	
	SOHC	89.0 x 93.0	3471	Alum, Crossflow	4	37mm SIR	2280	

GT2 Cars - ALFA ROMEO

Model	Years	Body Style	Drive-line	Wheel-base (in)	Notes
GTV	NA	2dr	RWD	94.5	Hood modifications allowed for carburetors.

Engines - ALFA ROMEO

Engine Family	Engine Type	Bore x Stroke (mm)	Disp. (cc)	Head Type	Valves/ Cyl.	Fuel Induction	Weight (lbs)	Notes
	SOHC	88.0 x 68.3	2492	Alum, Crossflow	2	46 IDA or (3) 48mm automotive type w/ 42mm choke(s)	2030	
	SOHC	93.0 x 72.6	2959	Alum, Crossflow	2	46 IDA or (3) 48mm automotive type w/ 42mm choke(s)	2180	

GT2 Cars - AUDI

Model	Years	Body Style	Drive-line	Wheel-base (in)	Notes
TT Coupe	NA	2dr	FWD	97.3	

Engines - AUDI

Engine Family	Engine Type	Bore x Stroke (mm)	Disp. (cc)	Head Type	Valves/ Cyl.	Fuel Induction	Weight (lbs)	Notes
	DOHC	82.5 x 92.8	1984	Alum, Crossflow	4	(2) automotive type w/ 48mm choke(s)	1850	

GT2 Cars - BLMI

Model	Years	Body Style	Drive-line	Wheel-base (in)	Notes
MGB GT V8 & RV8	NA	2dr	RWD	91.0	

Engines - BLMI

Engine Family	Engine Type	Bore x Stroke (mm)	Disp. (cc)	Head Type	Valves/ Cyl.	Fuel Induction	Weight (lbs)	Notes
	OHV	71.1 x 88.9	3528	Alum, Crossflow	2	38mm SIR	2280	

GT2 Cars - BMW

Model	Years	Body Style	Drive-line	Wheel-base (in)	Notes
325	84-91	2dr	RWD	101.2	
M3 (E30)	88-91	2dr	RWD	101.2	
M3 (E36)	95-99	2dr	RWD	106.3	
M3 (E46)	00-	2dr	RWD	106.3	
330ci (E46)	01-	2dr	RWD	107.3	

Engines - BMW

Engine Family	Engine Type	Bore x Stroke (mm)	Disp. (cc)	Head Type	Valves/ Cyl.	Fuel Induction	Weight (lbs)	Notes
S14	DOHC	93.4 x 84.0	2302	Alum, Crossflow	4	Unrestricted automotive type	2080	
M20	SOHC	84.1 x 75.0	2494	Alum, Crossflow	2	(3) 48mm w/ 40mm choke(s)	2080	
M50	DOHC	84.1 x 75.0	2494	Alum, Crossflow	4	Unrestricted automotive type	2280	
S50	DOHC	86.0 x 85.8	2990	Alum, Crossflow	4	(3) 45mm Weber w/ 38mm choke(s)	2280	
S52	DOHC	86.4 x 89.6	3152	Alum, Crossflow	4	36.5mm SIR	2280	

GT2 Cars - CHEVROLET

Model	Years	Body Style	Drive-line	Wheel-base (in)	Notes
Cavilier Z24	NA	2dr	FWD	104.0	
Monza	75-80	2dr	RWD	97.0	

Engines - CHEVROLET

Engine Family	Engine Type	Bore x Stroke (mm)	Disp. (cc)	Head Type	Valves/ Cyl.	Fuel Induction	Weight (lbs)	Notes
	DOHC	89.9 x 89.03	2210	Alum, Crossflow	4	37mm SIR	1950	GM racing block #XGB615 and cylinder head #XGBH614 allowed.
	DOHC	92.2 x 85.09	2272	Alum, Crossflow	2	(2) 48mm w/ 38mm choke(s)	2080	
	DOHC	90.0 x 94.0	2392	Alum, Crossflow	4	35mm SIR	2080	
	OHV	101.6 x 82.6	2679	Alum, Crossflow	2	(2) automotive type w/ 48mm choke(s)	2030	
	OHV	89.0 x 84.0	3136	Iron, Crossflow	2	Unrestricted automotive type or 39mm SIR	2150	

GT2 Cars - CHRYSLER/DODGE/PLYMOUTH

Model	Years	Body Style	Drive-line	Wheel-base (in)	Notes
Breeze / Stratus	NA	2dr	FWD	108.0	
Neon	NA	2dr, 4dr	FWD	104.0	
Daytona / Laser	84-87	2dr	FWD	97.0	Turbo Z body panels allowed.

Engines - CHRYSLER/DODGE/PLYMOUTH

Engine Family	Engine Type	Bore x Stroke (mm)	Disp. (cc)	Head Type	Valves/ Cyl.	Fuel Induction	Weight (lbs)	Notes
	SOHC	87.5 x 83.0	1995	Alum, Crossflow	4	Unrestricted automotive type	1950	
	DOHC	87.5 x 83.0	1995	Alum, Crossflow	4	Unrestricted automotive type	1950	
	SOHC	87.5 x 92.0	2213	Alum, Non-Crossflow	2	(2) automotive type w/ 50mm choke(s)	2080	

GT2 Cars - FERRARI

Model	Years	Body Style	Drive-line	Wheel-base (in)	Notes
308 GTB	76-	2dr	RWD	92.1	Fuel cell(s) must comply with GCR 9.3.26 but may be relocated to front trunk or remain in OEM saddle tank locations.
288, 328, 348, 355	NA	2dr	RWD	96.5	Fuel cell(s) must comply with GCR 9.3.26 but may be relocated to front trunk or remain in OEM saddle tank locations. Engine may be rotated longitudinally.

Engines - FERRARI

Engine Family	Engine Type	Bore x Stroke (mm)	Disp. (cc)	Head Type	Valves/ Cyl.	Fuel Induction	Weight (lbs)	Notes
	DOHC	81.0 x 71.0	2926	Alum, Crossflow	2	(4) Weber 40 DCNF	2280	
	DOHC	83.5 x 68.0	2980	Alum, Crossflow	4	37mm SIR	2280	

GT2 Cars - FORD

Model	Years	Body Style	Drive-line	Wheel-base (in)	Notes
Capri I, II	NA	2dr	RWD	100.8	
Mustang	74-78	2dr	RWD	100.8	
Mustang	79-93	2dr	RWD	100.5	
Probe	NA	2dr	FWD	99.0/102.9	

Engines - FORD

Engine Family	Engine Type	Bore x Stroke (mm)	Disp. (cc)	Head Type	Valves/ Cyl.	Fuel Induction	Weight (lbs)	Notes
	SOHC	91.0 x 77.0	1993	Alum, Crossflow	2	(2) Automotive type	1950	
	DOHC	84.5 x 74.2	2496	Alum, Crossflow	4	Unrestricted automotive type	2250	

Engines - FORD (cont.)								
Engine Family	Engine Type	Bore x Stroke (mm)	Disp. (cc)	Head Type	Valves/ Cyl.	Fuel Induction	Weight (lbs)	Notes
	OHV	90.0 x 66.8	2550	Iron, Crossflow	2	Unrestricted automotive type	2180	
	OHV	93.0 x 68.6	2796	Iron, Crossflow	2	Unrestricted automotive type	2180	
	OHV	93.0 x 72.6	2934	Iron, Crossflow	2	Unrestricted automotive type	2180	World Products 2.9 OHV cylinder head allowed.
GT2 Cars - INFINITI								
Model	Years	Body Style	Drive-line	Wheel-base (in)	Notes			
G20	99-02	4dr	FWD	102.4/97.5				
Engines - INFINITI								
Engine Family	Engine Type	Bore x Stroke (mm)	Disp. (cc)	Head Type	Valves/ Cyl.	Fuel Induction	Weight (lbs)	Notes
	DOHC	86.0 x 86.0	1998	Alum, Crossflow	4	Unrestricted automotive type	1950	
GT2 Cars - HONDA								
Model	Years	Body Style	Drive-line	Wheel-base (in)	Notes			
Prelude	93-	2dr	FWD	100.4				
Engines - HONDA								
Engine Family	Engine Type	Bore x Stroke (mm)	Disp. (cc)	Head Type	Valves/ Cyl.	Fuel Induction	Weight (lbs)	Notes
	DOHC	87.0 x 90.7	2157	Alum, Crossflow	4	Unrestricted automotive type	2180	VTEC not allowed.
	DOHC	86.9 x 95.0	2252	Alum, Crossflow	4	Unrestricted automotive type	2230	

GT2 Cars - JAGUAR

Model	Years	Body Style	Drive-line	Wheel-base (in)	Notes
XKE Coupe, Roadster	NA	2dr	RWD	96.0	Roadster windshield may be removed and a low front hoop roll cage fitted.

Engines - JAGUAR

Engine Family	Engine Type	Bore x Stroke (mm)	Disp. (cc)	Head Type	Valves/ Cyl.	Fuel Induction	Weight (lbs)	Notes
	DOHC	87.1 x 105.9	3781	Alum, Crossflow	2	(3) 2" SU or (2) 1.75" Stromberg or (3) 48mm auto-type on I.R. manifold	2250	
	DOHC	92.0 x 105.9	4235	Alum, Crossflow	2	(3) 2" SU or (2) 1.75" Stromberg or (3) 48mm auto-type on I.R. manifold	2250	

GT2 Cars - LOTUS

Model	Years	Body Style	Drive-line	Wheel-base (in)	Notes
Esprit	75-	2dr	RWD	96.0	

Engines - LOTUS

Engine Family	Engine Type	Bore x Stroke (mm)	Disp. (cc)	Head Type	Valves/ Cyl.	Fuel Induction	Weight (lbs)	Notes
	DOHC	95.3 x 76.2	2174	Alum, Crossflow	4	(2) automotive type w/ 48mm choke(s)	2180	

GT2 Cars - MAZDA

Model	Years	Body Style	Drive-line	Wheel-base (in)	Notes
MX-5 / Miata	90-	2dr	RWD	89.2	Rotary engine setback from the front spindle centerline to the front spark plug is 4.5".
RX-7	NA	2dr	RWD	95.2 / 95.5 / 95.7	
RX-8	NA	2dr	RWD	98.0	

Engines - MAZDA

Engine Family	Engine Type	Bore x Stroke (mm)	Disp. (cc)	Head Type	Valves/ Cyl.	Fuel Induction	Weight (lbs)	Notes
12A		Street Port	2292			40mm choke(s)	1880	
12A		Street / Bridge / Peripheral Port	2292			Unrestricted automotive type	1980	
13B		Street / Bridge Port	2616			(1) auto-type 2bbl w/ 44mm choke(s)	1980	
13B		Peripheral Port	2616			Unrestricted automotive type	2080	
ReGenesis		Street Port	2701			44mm choke(s)	1980	
	DOHC	89.0 x 79.5	2967	Alum, Crossflow	4	6 individual throttle bodies w/ 40mm choke(s)	2280	Hood bulge allowed.
20B		Street Port	3924			40mm SIR	2280	

GT2 Cars - MERCEDES BENZ

Model	Years	Body Style	Drive-line	Wheel-base (in)	Notes
190E	85-92	4dr	RWD	104.9	

Engines - MERCEDES BENZ

Engine Family	Engine Type	Bore x Stroke (mm)	Disp. (cc)	Head Type	Valves/ Cyl.	Fuel Induction	Weight (lbs)	Notes
	SOHC	82.9 x 80.3	2599	Alum, Crossflow	2	Unrestricted automotive type	2200	

GT2 Cars - MERCURY

Model	Years	Body Style	Drive-line	Wheel-base (in)	Notes
Capri	79-86	2dr	RWD	100.8	

Engines - MERCURY

Engine Family	Engine Type	Bore x Stroke (mm)	Disp. (cc)	Head Type	Valves/ Cyl.	Fuel Induction	Weight (lbs)	Notes
	OHV	93.0 x 68.6	2796	Iron, Crossflow	2	Unrestricted automotive type	2180	
	OHV	93.0 x 72.6	2934	Iron, Crossflow	2	Unrestricted automotive type	2180	World Products 2.9 OHV cylinder head allowed.

GT2 Cars - NISSAN

Model	Years	Body Style	Drive-line	Wheel-base (in)	Notes
240Z / 260Z / 280Z	-78	2dr	RWD	90.7	Headlight covers allowed.
280-Z 2 + 2	NA	2dr	RWD	102.6	
280-ZX	79-	2dr	RWD	91.3	
240-SX	NA	2dr	RWD	97.5	
240-SX S13	NA	2dr	RWD	97.5	Hood bulge allowed.
240-SX S14	NA	2dr	RWD	99.4	Hood bulge allowed.
300-ZX Z31	-89	2dr	RWD	91.3	Hood bulge allowed.
300-ZX Z32	90-	2dr	RWD	96.5/101.2	Hood bulge allowed.

GT2 Cars - NISSAN (cont.)

Model	Years	Body Style	Drive-line	Wheel-base (in)	Notes
350Z	NA	2dr	RWD	97.5 / 99.4 /104.3/90.7 /91.3/102.6 /104.3/91.3 /96.5/101.2 / 104.4	Doors may be pinned from the bottom at door bar height. Hood bulge allowed.

Engines - NISSAN

Engine Family	Engine Type	Bore x Stroke (mm)	Disp. (cc)	Head Type	Valves/ Cyl.	Fuel Induction	Weight (lbs)	Notes
SR20DE/VE	DOHC	86.0 x 86.0	1998	Alum, Crossflow	4	Unrestricted automotive type	1950	
L24	SOHC	83.0 x 73.3	2380	Alum, Non-Crossflow	2	(3) 50mm w/ 46mm choke(s)	2080	
KA24E	SOHC	89.0 x 96.0	2389	Alum, Crossflow	3	Unrestricted	2050	
KA24DE	DOHC	89.0 x 96.0	2389	Alum, Crossflow	4	37mm SIR	2080	
VQ25	DOHC	85.0 x 73.3	2495	Alum, Crossflow	4	35mm SIR	2130	Nismo cyl head #1104ORRZ30 and 1109ORRZ30 allowed.
L26	SOHC	83.0 x 79.0	2565	Alum, Non-Crossflow	2	(3) 50mm w/ 46mm choke(s)	2080	
VG30	DOHC	87.0 x 77.2	2754	Alum, Non-Crossflow	2	(3) 50mm w/ 46mm choke(s)	2080	
L28	SOHC	86.1 x 79.0	2760	Alum, Non-Crossflow	2	(3) 50mm w/ 46mm choke(s)	2080	
L28	SOHC	86.1 x 83.0	2899	Alum, Crossflow	2	(3) 50mm w/ 46mm choke(s)	2180	
VQ30	DOHC	87.0 x 83.0	2960	Alum, Crossflow	4	Automotive type sidedraft w/ 40mm choke(s) or 37mm SIR	2280 2230 w/ 37mm SIR	An SCCA approved F.I. kit of OEM origin is allowed. Contact the National Office for part numbers and specs. Nismo cyl head #1104ORRZ30 and 1109ORRZ30 allowed.
VQ30	DOHC	93.0 x 73.3	2988	Alum, Crossflow	4	Automotive type sidedraft w/ 40mm choke(s) or 37mm SIR	2280	Nismo cyl head #1104ORRZ30 and 1109ORRZ30 allowed.

Engines - NISSAN (cont.)

Engine Family	Engine Type	Bore x Stroke (mm)	Disp. (cc)	Head Type	Valves/ Cyl.	Fuel Induction	Weight (lbs)	Notes
VQ35 w/ VQ30 crankshaft	DOHC	95.5 x 73.3	3150.3	Alum, Crossflow	4	37mm SIR	2280	Nismo cyl head #11040RRZ30 and 11090RRZ30 allowed.
VQ30 w/ VQ35 crankshaft	DOHC	93.0 x 81.4	3317.7	Alum, Crossflow	4	37mm SIR	2280	Nismo cyl head #11040RRZ30 and 11090RRZ30 allowed.
VQ35	DOHC	95.5 x 81.4	3498	Alum, Crossflow	4	37mm SIR	2280	Nismo cyl head #11040RRZ30 and 11090RRZ30 allowed.

GT2 Cars - PANOZ

Model	Years	Body Style	Drive-line	Wheel-base (in)	Notes
Esperante GTS	NA	2dr	RWD	107.6	Cars must be prepared to Panoz Esperante GTS specifications and competitors must have a copy of the current GTS rules in their possession. Wheels: (F) 18x10 (R)18x11, Track (F) 64.0 (R)67.8. Any tire with a diameter of 17" or 18" may be used provided the tire does not exceed a maximum cross section width of 11.5" in the front and 12.5" in the rear.

Engines - PANOZ

Engine Family	Engine Type	Bore x Stroke (mm)	Disp. (cc)	Head Type	Valves/ Cyl.	Fuel Induction	Weight (lbs)	Notes
	OHV	101.6 x 88.9	5754	Alum, Crossflow	2	Holly 4bbl. 750 cfm #0-4779C. ProForm 67100C throttle body - Panoz part #GTS6-3349 allowed.	2880	Maximum compression ratio of 10.5:1. Fresh air intake air cleaner housing Panoz #GTS9-3348 allowed.

GT2 Cars - PONTIAC

Model	Years	Body Style	Drive-line	Wheel-base (in)	Notes
Fiero	NA	2dr	FWD	93.4	May convert to front engine/rear wheel drive. If OEM engine location is used (i.e. rear-engine) IRS weight penalty is waived. Air cleaner may protrude through engine hatch.
Grand Am	NA	2dr	FWD	103.4	
Sunfire GT	NA	2dr	FWD	104.0	

Engines - PONTIAC

Engine Family	Engine Type	Bore x Stroke (mm)	Disp. (cc)	Head Type	Valves/ Cyl.	Fuel Induction	Weight (lbs)	Notes
	DOHC	86.0 x 94.6	2198	Alum, Crossflow	4	37mm SIR	1950	
LE5 Ecotech	DOHC	88.9 x 89.03	2210	Alum, Crossflow	4	37mm SIR	1950	GM racing block #XGB615 and cylinder head #XGBH614 allowed.
	DOHC	92.2 x 85.09	2272	Alum, Crossflow	4	(2) 48mm w/ 38mm choke(s)	2080	
	DOHC	90.0 x 94.0	2392	Alum, Crossflow	4	35mm SIR	2080	
	OHV	101.6 x 76.2	2471	Iron, Crossflow	2	(2) Automotive type w/ 48mm choke(s)	1930	
	OHV	101.6 x 82.6	2679	Iron, Crossflow	2	(2) Automotive type w/ 48mm choke(s)	2030	
	OHV	89.0 x 76.0	2837	Iron, Crossflow	2	Unrestricted automotive type or 39mm SIR	2080	Factory aluminum cylinder heads allowed.
	OHV	89.0 x 84.0	3136	Iron, Crossflow	2	Unrestricted automotive type or 39mm SIR	2150	
	OHV	92.0 x 84.0	3350	Iron, Crossflow	2	Unrestricted automotive type or 39mm SIR	2230	
	OHV	94.0 x 84.0	3498	Iron, Crossflow	2	Unrestricted automotive type or 39mm SIR	2280	

GT2 Cars - PORSCHE

Model	Years	Body Style	Drive-line	Wheel-base (in)	Notes
911 Coupe & Targa	68-	2dr	RWD	89.4	Factory spoiler: 930-512-023-00 & 530-512-021-00 (or kit #930-512-901-01), no reproductions. Windshield may be removed on Targa and a low front hoop roll cage may be fitted.
914-6	NA	2dr	RWD	96.5	Top panels may remain if bolted or pinned. Roof of alt. material allowed. Windshield may be removed and a low front roll cage may be fitted. 75-76 bumpers allowed.

GT2 Cars - PORSCHE (cont.)

Model	Years	Body Style	Drive-line	Wheel-base (in)	Notes
944	NA	2dr	RWD	94.5	
968	NA	2dr	RWD	94.5	
Boxster	NA	2dr	RWD	95.1	Top panels may remain if bolted or pinned. Roof of alt. material allowed. Windshield may be removed and a low front roll cage may be fitted.
996 GT3 Cup	98-05	2dr	RWD	92.5	Cars must be prepared to Porsche Cup Specifications except that cars must meet all SCCA safety standards unless otherwise noted. Competitors must have a current copy of the Porsche Cup rules in their possession. An alternate hood is allowed provided it is a facsimile of the stock part. Original, factory-installed Matter/IMV roll cage allowed. Any wheel, including 5-bolt, may be used provided it does not exceed 18x9 (F) and 18x11 (R). Battery size and location is unrestricted. Shocks are unrestricted but they shall be installed in the stock location using the stock pick-up points. Side window glass must be removed and windshield clips must be installed per GCR section 9.3.52. The stock unmodified fuel tank is allowed.

Engines - PORSCHE

Engine Family	Engine Type	Bore x Stroke (mm)	Disp. (cc)	Head Type	Valves/Cyl.	Fuel Induction	Weight (lbs)	Notes
	SOHC	80.0 x 66.0	1991	Alum, Crossflow	2	(2) Automotive type w/ 46mm choke(s)	2030	OEM 2-valve air-cooled heads may be modified to utilize two spark plugs per cylinder. Alt. head: 911-104-302-OR (w/ sealed injector port).
	SOHC	84.0 x 66.0	2195	Alum, Crossflow	2	(2) Automotive type w/ 46mm choke(s)	2030	OEM 2-valve air-cooled heads may be modified to utilize two spark plugs per cylinder. Alt. head: 911-104-302-OR (w/ sealed injector port).
	SOHC	84.0 x 70.4	2341	Alum, Crossflow	2	(2) Automotive type w/ 46mm choke(s)	2030	
	SOHC	100.0 x 78.9	2478	Alum, Crossflow	2	(2) Weber-type w/ 48mm choke(s)	2080	Alt. 4 valve head #944 104 013 03.
	DOHC	85.5 x 72.0	2480	Alum, Crossflow	4	(2) Weber-type w/ 34mm choke(s)	2080	
	SOHC	104.0 x 78.9	2681	Alum, Crossflow	2	35.5mm SIR	2150	
	DOHC	90.0 x 70.4	2687	Alum, Crossflow	4	36mm SIR	2180	

Engines - PORSCHE (cont.)

Engine Family	Engine Type	Bore x Stroke (mm)	Disp. (cc)	Head Type	Valves/ Cyl.	Fuel Induction	Weight (lbs)	Notes
	SOHC	100.0 x 88.0	2766	Alum, Crossflow	2	36mm SIR	2180	
	SOHC	95.0 x 70.4	2808	Alum, Crossflow	2	(2) Automotive type w/ 46mm choke(s)	2030	
	DOHC	104.0 x 88.0	2981	Alum, Crossflow	4	Unrestricted automotive type	2180	
	SOHC	95.0 x 70.4	2992	Alum, Crossflow	2	(2) Automotive type w/ 46mm choke(s)	2080	
	DOHC	93.0 x 78.0	3179	Alum, Crossflow	4	40mm choke(s)	2380	
	DOHC	Unspecified	3200	Alum, Crossflow	2	(2) Automotive type w/ 46mm choke(s)	2160	
	DOHC	Unspecified	3400	Alum, Crossflow	2	(2) Automotive type w/ 46mm choke(s)	2220	
	DOHC	Unspecified	3600	Alum, Crossflow	2	35.5mm SIR	2160	
	DOHC	Unspecified	3600	Alum, Crossflow	2	Unrestricted automotive type	2280	
	DOHC	Unspecified	3800	Alum, Crossflow	2	36.5mm SIR	2280	
	DOHC	Unspecified	380	Alum, Crossflow	2	Unrestricted automotive type	2380	
	DOHC	100.0 x 76.4	3595	Alum, Crossflow	4	OEM fuel injection w/ stock, unmodified throttle body	2730	Porsche Cup car only. Must run fuel meeting the specs for IT cars per the Porsche Cup rules.

GT2 Cars - SUNBEAM

Model	Years	Body Style	Drive-line	Wheel-base (in)	Notes
Tiger	NA	2dr	RWD	86.0	Windshield may be removed and a low front hoop roll cage may be fitted.

Engines - SUNBEAM

Engine Family	Engine Type	Bore x Stroke (mm)	Disp. (cc)	Head Type	Valves/ Cyl.	Fuel Induction	Weight (lbs)	Notes
	OHV	96.5 x 72.9	4265	Iron, Crossflow	2	Ford C30 FAB, C30F-9510E, C40F-9519-1E*	2280	Cylinder Heads: Any Ford 260, 289, or 302 Windsor V-8 cast-iron production cylinder head, delivered on U.S. model cars or trucks, and bearing unmodified factory casting numbers beginning in C, D, E, or F are allowed. Competitor shall be able to provide documentation from the manufacturer identifying application(s), displacement, engine family, and casting identification. Ford Motorsport engine blocks (P/N M-6010-A50 & M-6010-B50) are allowed.
	OHV	101.6 x 72.9	4728	Iron, Crossflow	2	*Manifold: Stock Sunbeam Tiger manifold only. Holley P/N 0-80507-1 (390 CFM) on unrestricted manifold. A restrictor plate between the carburetor and plenum is mandatory for cars running the 390cfm carburetor: 0.060" flat steel or aluminum plate with four (4) 1 1/16" holes. Spacer is unrestricted. The restrictor plate shall be positioned within 4" of the throttle butterflies. All inducted air shall pass through the specified restrictor plate.	2280	

GT2 Cars - TOYOTA

Model	Years	Body Style	Drive-line	Wheel-base (in)	Notes
Celica incl. GTS	82-89	2dr	FWD	99.4	
Celica incl. GTS	90-05	2dr	RWD	99.4	RWD only.
MR-2	91-	2dr	RWD	94.5	No factory rear spoiler/wing. Fuel cell may be relocated to front trunk area. 3S front engine - rear drive conversion @ 1950 lbs.

GT2 Cars - TOYOTA (cont.)

Model	Years	Body Style	Drive-line	Wheel-base (in)	Notes
Solara	00-	2dr	FWD	107.1 / 102.4/97.0	
Supra	NA	2dr	RWD	94.5	

Engines - TOYOTA

Engine Family	Engine Type	Bore x Stroke (mm)	Disp. (cc)	Head Type	Valves/ Cyl.	Fuel Induction	Weight (lbs)	Notes
3S	DOHC	86.0 x 86.0	1998	Alum, Crossflow	4	Automotive type sidedraft	1950	
5S	DOHC	87.0 x 91.0	2164	Alum, Crossflow	4	Automotive type sidedraft	1950	
2RZ	DOHC	95.0 x 86.0	2438	Alum, Crossflow	4	37mm SIR	2080	
5M	DOHC	83.0 x 85.0	2759	Alum, Crossflow	2	(3) 45mm Weber w/ 38mm choke(s)	2180	
1MZ	DOHC	87.5 x 83.0	2995	Alum, Crossflow	4	6 individual throttle bodies w/ 40mm choke(s) or 37mm SIR	2280	
2GR	DOHC	94.0 x 86.36	3594	Alum, Crossflow	4	37mm SIR	2280	

GT2 Cars - VOLKSWAGEN

Model	Years	Body Style	Drive-line	Wheel-base (in)	Notes
Corrado	NA	2dr	FWD	97.3	
Golf incl. GTI	NA	2dr	FWD	97.3	

Engines - VOLKSWAGEN

Engine Family	Engine Type	Bore x Stroke (mm)	Disp. (cc)	Head Type	Valves/ Cyl.	Fuel Induction	Weight (lbs)	Notes
	DOHC	82.5 x 92.8	1984	Alum, Crossflow	4	(2) Automotive type w. 48mm choke(s)	1980	
	DOHC	81.0 x 90.3	2782	Alum, Crossflow	4	(2) Automotive type w. 48mm choke(s)	2280	

GT3 Cars - ACURA								
Model	Years	Body Style	Drive-line	Wheel-base (in)	Notes			
Integra	-93	2dr	FWD	96.5				
Integra	94-	2dr	FWD	101.2				
RSX	02-05	2dr	FWD	96.5/101.2				
Engines - ACURA								
Engine Family	Engine Type	Bore x Stroke (mm)	Disp. (cc)	Head Type	Valves/ Cyl.	Fuel Induction	Weight (lbs)	Notes
D16A	SOHC	74.9 x 89.9	1590	Alum, Crossflow	4	(2) 48mm w/ 42mm choke(s).	1900	
B16A	DOHC	81.0 x 77.4	1595	Alum, Crossflow	4	(2) 48mm w/ 42mm choke(s).	2000	
B18C	DOHC	81.0 x 87.2	1797	Alum, Crossflow	4	(2) 48mm w/ 42mm choke(s).	2000	
B18B	DOHC	81.0 x 89.0	1834	Alum, Crossflow	4	(2) 45mm w/ 38mm choke(s)	2100	
F20C	DOHC	87.0 x 84.0	1997	Alum, Crossflow	4	31mm SIR	2000	
K20A	DOHC	86.0 x 86.0	1998	Alum, Crossflow	4	33mm SIR	2100	
K24	DOHC	87.0 x 99.0	2354	Alum, Crossflow	4	33mm SIR	2280 2180 w/ 31mmSIR	
GT3 Cars - ALFA ROMEO								
Model	Years	Body Style	Drive-line	Wheel-base (in)	Notes			
GTV 1750 / 2000	NA	2dr	RWD	92.5				
Sport Sedan	NA	2dr	RWD	98.8				

Engines - ALFA ROMEO

Engine Family	Engine Type	Bore x Stroke (mm)	Disp. (cc)	Head Type	Valves/ Cyl.	Fuel Induction	Weight (lbs)	Notes
	DOHC	80.0 x 88.5	1779	Alum, Crossflow	2	Unrestricted	1800	Alt. Head: 19510-01053-04 (twin plug), w/ 100 lb. penalty.
	DOHC	84.0 x 88.5	1962	Alum, Crossflow	2	Unrestricted	2000	Alt. Head: 19510-01053-04 (twin plug), w/ 100 lb. penalty.

GT3 Cars - AMC

Model	Years	Body Style	Drive-line	Wheel-base (in)	Notes
Gremlin	-78	2dr	RWD	96.0	
Spirit	79-	2dr	RWD	96.0	

Engines - AMC

Engine Family	Engine Type	Bore x Stroke (mm)	Disp. (cc)	Head Type	Valves/ Cyl.	Fuel Induction	Weight (lbs)	Notes
	OHV	95.3 x 88.8	2537	Iron, Crossflow	2	Holley 5210/2V	2380	
	OHV	95.3 x 88.9	3805	Iron, Crossflow	2	Carter YF-1V, Holley 500 CFM 2bbi.	2600	

GT3 Cars - AUDI

Model	Years	Body Style	Drive-line	Wheel-base (in)	Notes
TT Coupe	NA	2dr	FWD	95.6 / 97.3	

Engines - AUDI

Engine Family	Engine Type	Bore x Stroke (mm)	Disp. (cc)	Head Type	Valves/ Cyl.	Fuel Induction	Weight (lbs)	Notes
	SOHC	82.5 x 92.8	1984	Alum, Crossflow	2	(2) 50mm w/ 50mm choke(s)	1800	Alt. Eurospec Sports cyl. head may be used.
	DOHC	82.5 x 92.8	1984	Alum, Crossflow	4	33mm SIR	2000	

GT3 Cars - BMW

Model	Years	Body Style	Drive-line	Wheel-base (in)	Notes
2002 / 2002ti/tii	NA	2dr	RWD	100.5/98.5	
318 Coupe (E36)	92-	2dr	RWD	106.0	
318i (E30)	83-91	4dr	RWD	101.2	
318i / 320i (E21)	77-82	4dr	RWD	100.9	
E46	00-	2, 4dr	RWD	106.0 / 101.2 / 100.9	
Z3	NA	2dr	RWD	96.3	

Engines - BMW

Engine Family	Engine Type	Bore x Stroke (mm)	Disp. (cc)	Head Type	Valves/ Cyl.	Fuel Induction	Weight (lbs)	Notes
	SOHC	89.0 x 71.0	1767	Alum, Crossflow	2	Unrestricted	1800	
	DOHC	84.0 x 81.0	1796	Alum, Crossflow	4	(2) 45mm w/ 45mm choke(s)	2010	
	DOHC	85.0 x 83.5	1895	Alum, Crossflow	4	(2) 45mm w/ 45mm choke(s)	2010	
	SOHC	89.0 x 80.0	1991	Alum, Crossflow	2	Unrestricted	1810	
	DOHC	93.4 x 84.0	2302	Alum, Crossflow	4	33mm SIR	2280 2180 w/ 31mmSIR	

GT3 Cars - CHEVROLET

Model	Years	Body Style	Drive-line	Wheel-base (in)	Notes
Vega	NA	2dr	RWD	97.0	
Corvaire Coupe / Yenke Stinger	NA	2dr	RWD	108.0	Corvaire coupes may be modified to Yenke configuration. Non-tube frame track 59.7 (F), 62.9 (R). Rear wheel width: 8". Engine may be centered (side to side) to allow installation of alternate transaxle.
Cavalier Z-24	NA	2dr	FWD	101.2	

Engines - CHEVROLET

Engine Family	Engine Type	Bore x Stroke (mm)	Disp. (cc)	Head Type	Valves/ Cyl.	Fuel Induction	Weight (lbs)	Notes
	SOHC	86.0 x 86.0	1998	Alum, Crossflow	2	Unrestricted	2000	
	DOHC	88.9 x 80.3	1998	Alum, Crossflow	4	Unrestricted	2300	
	SOHC	88.9 x 92.1	2287	Iron, Non-Crossflow	2	Unrestricted	2180	
	OHV	87.4 x 74.7	2689	Alum, Crossflow	2	(2) Weber 40 IDT or IDA w/ 36mm choke(s), or (4) Rochester 7025023 & 7026026 1.5" 1bbl carbs.	2225	

GT3 Cars - CHRYSLER/DODGE/PLYMOUTH

Model	Years	Body Style	Drive-line	Wheel-base (in)	Notes
Neon	NA	2dr, 4dr	FWD	104.0	
Daytona / Laser	84-88	2dr	FWD	97.0	
Daytona / Laser	89-	2dr	FWD	97.3	

GT3 Cars - CHRYSLER/DODGE/PLYMOUTH (cont.)

Model	Years	Body Style	Drive-line	Wheel-base (in)	Notes
Horizon	NA	2dr	FWD	96.7	
Omni 024 / Shelby Charger	79-82	2dr	FWD	96.6	
Shadow	NA	2dr	FWD	97.0	

Engines - CHRYSLER/DODGE/PLYMOUTH

Engine Family	Engine Type	Bore x Stroke (mm)	Disp. (cc)	Head Type	Valves/ Cyl.	Fuel Induction	Weight (lbs)	Notes
	DOHC	85.0 x 88.0	1997	Alum, Crossflow	4	(2) 45mm w/ 34mm choke(s)	2150	
	SOHC	85.0 x 88.0	1997	Alum, Crossflow	2	(2) 45mm w/ 45mm choke(s)	1900	
	SOHC	87.5 x 92.0	2213	Alum, Non-Crossflow	2	(2) 45mm w/ 45mm choke(s)	2030	

GT3 Cars - FIAT

Model	Years	Body Style	Drive-line	Wheel-base (in)	Notes
131 Coupe & Sedan, Brava	NA	2dr, 4dr	RWD	98.0	

Engines - FIAT

Engine Family	Engine Type	Bore x Stroke (mm)	Disp. (cc)	Head Type	Valves/ Cyl.	Fuel Induction	Weight (lbs)	Notes
	DOHC	84.1 x 89.9	1995	Alum, Crossflow	2	Unrestricted	2000	

GT3 Cars - FORD

Model	Years	Body Style	Drive-line	Wheel-base (in)	Notes
Capri	NA	2dr	RWD	100.8	
Mustang II	74-78	2dr	RWD	96.2	
Mustang	79-93	2dr	RWD	100.4	
Mustang	94-98	2dr	RWD	101.2	
Pinto	NA	2dr	RWD	94.0	Non-tube frame track: 60.52 (F&R). Spoiler: #D9FZ-6440555-A, End Pieces: D9FZ-6428010-A and D9FZ-6428011-A.
Probe	NA	2dr	FWD	99.0/102.9	

Engines - FORD

Engine Family	Engine Type	Bore x Stroke (mm)	Disp. (cc)	Head Type	Valves/ Cyl.	Fuel Induction	Weight (lbs)	Notes
	SOHC	91.0 x 77.0	1993	Iron, Crossflow	2	Unrestricted	1900	
	SOHC	96.0 x 79.4	2301	Iron, Crossflow	2	Unrestricted	2080	Alt. head: SVO #M-6049-A230 w/ 45mm choke(s).
	SOHC	86.0 x 86.0	1998	Alum, Crossflow	2	(2) 48mm w/ 42mm choke(s)	1900	
	SOHC	86.0 x 94.0	2189	Alum, Crossflow	3	(2) 45mm w/ 38mm choke(s)	2180 2080 w/ 31mmSIR	
Duratech	DOHC	87.5 x 94.0	2260	Alum, Crossflow	4	33mm SIR	2280 2180 w/ 31mmSIR	

GT3 Cars - HONDA

Model	Years	Body Style	Drive-line	Wheel-base (in)	Notes
Civic	88-91	3dr	FWD	90.6	Hood bulge allowed, no openings.
Civic Coupe	92-95	2dr	FWD	98.4	
CRX	84-87	3dr	FWD	86.6	
CRX	88-91	3dr	FWD	90.6	Hood bulge allowed, no openings.

Engines - HONDA

Engine Family	Engine Type	Bore x Stroke (mm)	Disp. (cc)	Head Type	Valves/Cyl.	Fuel Induction	Weight (lbs)	Notes
EW	SOHC	74.0 x 86.5	1488	Alum, Crossflow	3	Unrestricted	1820	Alt. heads: #12100-PE3-000 or #12100-PE7-000.
D15B	SOHC	75.0 x 84.5	1493	Alum, Crossflow	4	(2) 45mm w/ 45mm choke(s)	1900	
D16A	SOHC	75.0 x 90.0	1590	Alum, Crossflow	4	(2) 48mm w/ 42mm choke(s)	1900	
B16A	DOHC	81.0 x 77.4	1595	Alum, Crossflow	4	(2) 48mm w/ 42mm choke(s)	2000	
B18C	DOHC	81.0 x 87.2	1797	Alum, Crossflow	4	(2) 48mm w/ 42mm choke(s)	2000	
B18B	DOHC	81.0 x 89.0	1834	Alum, Crossflow	4	(2) 45mm w/ 38mm choke(s)	2100	
F20C	DOHC	87.0 x 84.0	1997	Alum, Crossflow	4	31mm SIR	2000	
K20A	DOHC	86.0 x 86.0	1998	Alum, Crossflow	4	33mm SIR	2100	
K24	DOHC	87.0 x 99.0	2354	Alum, Crossflow	4	33mm SIR	2280 2180 w/ 31mmSIR	

GT3 Cars - MAZDA

Model	Years	Body Style	Drive-line	Wheel-base (in)	Notes
626	83-87	4dr	FWD	98.8	Rotary engine setback from the front spindle centerline to the front spark plug is 4.5".
MX-3	NA	2dr	FWD	96.3	Rotary engine setback from the front spindle centerline to the front spark plug is 4.5".
MX-5 / Miata	-05	2dr	RWD	89.2 / 91.0	Rotary engine setback from the front spindle centerline to the front spark plug is 4.5".
MX-5	2006	2dr	RWD	91.7	Rotary engine setback from the front spindle centerline to the front spark plug is 4.5".
MX-6	88-	2dr	FWD	99.0/102.8	Rotary engine setback from the front spindle centerline to the front spark plug is 4.5".
RX-2	NA	2dr	RWD	97.3	
RX-3	NA	2dr	RWD	91.0	
RX-7	NA	2dr	RWD	95.3 / 95.5 / 95.7	Non-tube frame track: 63.2 (F), 62.8 (R).
RX-8	NA	2dr	RWD	98.0	
Protégé	NA	4dr	FWD	98.4	Rotary engine setback from the front spindle centerline to the front spark plug is 4.5".

Engines - MAZDA

Engine Family	Engine Type	Bore x Stroke (mm)	Disp. (cc)	Head Type	Valves/ Cyl.	Fuel Induction	Weight (lbs)	Notes
B6D	DOHC	78.0 x 83.6	1597	Alum, Crossflow	4	(2) auto-type w/ 42mm choke(s).	1900	
BP	DOHC	83.0 x 85.0	1839	Alum, Crossflow	4	(2) auto-type w/ 38mm choke(s).	2020	
	SOHC	86.0 x 86.0	1998	Alum, Crossflow	2	(2) auto-type w/ 42mm choke(s).	1900	
MZR	DOHC	87.38 x 83.06	1999	Alum, Crossflow	4	33mm SIR	2000	
	SOHC	86.0 x 94.0	2189	Alum, Crossflow	2	(2) auto-type w/ 38mm choke(s).	1980	
MZR	DOHC	87.5 x 94.0	2260	Alum, Crossflow	4	33mm SIR	2280 2180 w/ 31mmSIR	Hood bulge allowed w/ no openings.

Engines - MAZDA (cont.)

Engine Family	Engine Type	Bore x Stroke (mm)	Disp. (cc)	Head Type	Valves/ Cyl.	Fuel Induction	Weight (lbs)	Notes
12A		Street Port	2292			(1) auto-type 2bbl w/ 42mm choke(s).	2000	
12A		Bridge Port	2292			(1) auto-type 2bbl w/ 40mm choke(s).	2000	
12A		Peripheral Port	2292			37mm SIR	2180	
13B		Street Port	2616			Unrestricted	2180	
13B		Bridge / Peripheral Port	2616			37mm SIR	2180	
Renesis		Street Port	2703			Unrestricted	2180	
Renesis		Bridge / Peripheral Port	2703			37mm SIR	2180	

GT3 Cars - MERCURY

Model	Years	Body Style	Drive-line	Wheel-base (in)	Notes
Capri	79-86	2dr	FWD	100.4	
Cougar	99-02	2dr	FWD	103.0 / 106.4	

Engines - MERCURY

Engine Family	Engine Type	Bore x Stroke (mm)	Disp. (cc)	Head Type	Valves/ Cyl.	Fuel Induction	Weight (lbs)	Notes
	SOHC	91.0 x 77.0	1993	Iron, Crossflow	2	Unrestricted	1900	
	SOHC	96.0 x 79.4	2301	Iron, Crossflow	2	Unrestricted	2180	Alt. Head: SVO #M-6049-A230 w/ 45mm chokes).

GT3 Cars - MITSUBISHI / EAGLE

Model	Years	Body Style	Drive-line	Wheel-base (in)	Notes
Talon	NA	2dr	FWD	97.3	
Eclipse	NA	2dr	FWD	97.3	

Engines - MITSUBISHI / EAGLE

Engine Family	Engine Type	Bore x Stroke (mm)	Disp. (cc)	Head Type	Valves/ Cyl.	Fuel Induction	Weight (lbs)	Notes
	DOHC	85.0 x 88.0	1997	Alum, Crossflow	4	(2) 45mm w/ 34mm choke(s).	2150	
	SOHC	85.0 x 88.0	1997	Alum, Crossflow	2	(2) 45mm w/ 45mm choke(s).	1900	
	SOHC	97.5 x 92.0	2213	Alum, Non-Crossflow	2	(2) 45mm w/ 45mm choke(s).	2030	

GT3 Cars - NISSAN

Model	Years	Body Style	Drive-line	Wheel-base (in)	Notes
200-SX / S10	77-79	2dr	RWD	92.1	
200-SX / S11	80-83	2dr	RWD	94.5	
200-SX / S12	84-88	2dr	RWD	95.5	
200-SX SER	95-97	2dr	RWD	95.7 / 99.8	
240-SX / S13	NA	2dr	RWD	97.5	Hood bulge allowed, no openings.
240-SX / S14	NA	2dr	RWD	99.4	Hood bulge allowed, no openings.
240Z / 260Z / 280Z	NA	2dr	RWD	90.7	
280-ZX	-79	2dr	RWD	91.3	
300-ZX	NA	2dr	RWD	91.3 / 96.5 / 101.2	

GT3 Cars - NISSAN (cont.)

Model	Years	Body Style	Drive-line	Wheel-base (in)	Notes
350Z	NA	2dr	RWD	95.3 / 98.4 / 104.3 / 94.5 / 92.1 / 95.3 / 97.5 / 99.4 / 104.3	
710	NA	2, 4dr	RWD	98.4	
PL510	NA	2, 4dr	RWD	95.3	
Sentra SER Spec V	2002	4dr	FWD	95.7	

Engines - NISSAN

Engine Family	Engine Type	Bore x Stroke (mm)	Disp. (cc)	Head Type	Valves/ Cyl.	Fuel Induction	Weight (lbs)	Notes
L18	SOHC	85.0 x 78.0	1770	Alum, Non-Crossflow	2	Unrestricted	1800	Alt. Heads: #11041-22010, 11041-U0600-A, 11041-U0602-SV, 11041-21901, 11041-N7120.
L20	SOHC	85.0 x 86.0	1952	Alum, Non-Crossflow	2	50mm w/ 50mm choke(s)	1780	Alt. Heads: #11041-22010, 11041-U0600-A, 11041-U0602-SV, 11041-21901, 11041-N7120.
	SOHC	84.5 x 88.0	1974	Alum, Crossflow	2	50mm w/ 50mm choke(s)	1900	
SR20DE/VE	DOHC	86.0 x 86.0	1998	Alum, Crossflow	4	33mm SIR	2000	High port (89-94) and low port (95-01) allowed.
L20 w/ Z22 block	SOHC	87.0 x 86.0	2045	Alum, Non-Crossflow	2	50mm w/ 50mm choke(s)	1830	
NAPZ	SOHC	87.0 x 92.0	2188	Alum, Non-Crossflow	2	50mm w/ 50mm choke(s)	1930	
L24	SOHC	83.0 x 73.3	2380	Alum, Non-Crossflow	2	33mm SIR	2200	
KA24E	SOHC	89.0 x 96.0	2389	Alum, Crossflow	3	(2) 45mm w/ 34mm choke(s)	2280 2180 w/ 31mmSIR	An SCCA approved F.I. kit of OEM origin is allowed. Contact the SCCA National Office for p/n's and specs.
KA24DE	DOHC	89.0 x 96.0	2389	Alum, Crossflow	4	33mm SIR	2280 2180 w/ 31mmSIR	

Engines - NISSAN (cont.)

Engine Family	Engine Type	Bore x Stroke (mm)	Disp. (cc)	Head Type	Valves/ Cyl.	Fuel Induction	Weight (lbs)	Notes
L26	SOHC	83.0 x 79.0	2565	Alum, Non-Crossflow	2	33mm SIR	2200	
L28	SOHC	86.1 x 79.0	2760	Alum, Non-Crossflow	2	33mm SIR	2200	
VG30	SOHC	86.1 x 83.0	2899	Alum, Crossflow	2	33mm SIR	2200	

GT3 Cars - PONTIAC

Model	Years	Body Style	Drive-line	Wheel-base (in)	Notes
Fiero	NA	2dr	RWD	93.4	May convert to front engine/rear wheel drive. If OEM engine location is used (rear engine) IRS weight penalty is waived. Air cleaner may protrude through engine hatch.

Engines - PONTIAC

Engine Family	Engine Type	Bore x Stroke (mm)	Disp. (cc)	Head Type	Valves/ Cyl.	Fuel Induction	Weight (lbs)	Notes
	OHV	101.6 x 82.55	2677	Alum, Crossflow	2	33mm SIR	2200	

GT3 Cars - PORSCHE

Model	Years	Body Style	Drive-line	Wheel-base (in)	Notes
911 Coupe & Targa	68-	2dr	RWD	87.0 / 89.4	Windshield may be removed on Targa and a low front hoop may be fitted. Rear rim width: 8". Factory spoiler: #930-512-023-00 & 930-512-021-00 (or kit #930-512-901-01). No alternate materials or reproductions.
914	NA	2dr	RWD	96.5	Top panels may remain if securely bolted or pinned. Windshield may be removed and a low front hoop roll cage fitted. (75-76) bumpers allowed.
924	NA	2dr	RWD	94.5	
944	NA	2dr	RWD	94.5	
Boxster	NA	2dr	RWD	96.5	

Engines - PORSCHE								
Engine Family	Engine Type	Bore x Stroke (mm)	Disp. (cc)	Head Type	Valves/ Cyl.	Fuel Induction	Weight (lbs)	Notes
	OHV	94.0 x 70.9	1968	Alum, Crossflow	2	(2) auto-type w/ (1) throat per cyl.	1800	Intake manifold: #021-129-705R. Cylinder barrels may be of alternate material. Alt. head: Type 1/Type 3. OEM 2-valve air cooled heads may be modified to utilize two (2) spark plugs per cylinder.
	SOHC	86.5 x 84.4	1984	Alum, Crossflow	2	(2) Weber 45 DCOE w/ 42mm choke(s)	2000	Alt. Head: #933-104-302-50.
	SOHC	80.0 x 66.0	1991	Alum, Crossflow	2	(2) 40 IDA/IDS/IDT 3C, (6) Solex 40 Pl, or (2) 46 IDA/IDS w/ 40mm choke(s).	1950	OEM 2-valve air cooled heads may be modified to utilize two (2) spark plugs per cyl. Alt Head: 911-104-302-OR (w/sealed injector port).
	SOHC	84.0 x 66.0	2195	Alum, Crossflow	2	(2) 40 IDA/IDS/IDT 3C, (6) Solex 40 Pl, or (2) 46 IDA/IDS w/ 40mm choke(s).	2030	OEM 2-valve air cooled heads may be modified to utilize two (2) spark plugs per cyl.
	SOHC	84.0 x 70.4	2341	Alum, Crossflow	2	33mm SIR	2200	
	SOHC	100.0 x 78.9	2478	Alum, Crossflow	2	34mm SIR	2215	Alt. 4 valve head: #944 104 013 03 w/ 31mm SIR @ 2215 lbs or 33mm SIR @ 2315.
	SOHC	100.4 x 78.9	2681	Alum, Crossflow	2	33mm SIR	2200	
	SOHC	90.0 x 70.4	2687	Alum, Crossflow	2	33mm SIR	2200	
	SOHC	100.0 x 88.0	2766	Alum, Crossflow	2	33mm SIR	2200	
	SOHC	92.0 x 70.4	2808	Alum, Crossflow	2	33mm SIR	2200	
	SOHC	95.0 x 70.4	2992	Alum, Crossflow	2	33mm SIR	2200	OEM 2-valve air cooled heads may be modified to utilize two (2) spark plugs per cyl.

GT3 Cars - SAAB

Model	Years	Body Style	Drive-line	Wheel-base (in)	Notes
900	79-	2dr	FWD	99.4	
99E, CM, EMS, GL, LE	NA	2, 4dr	RWD	97.4	

Engines - SAAB

Engine Family	Engine Type	Bore x Stroke (mm)	Disp. (cc)	Head Type	Valves/ Cyl.	Fuel Induction	Weight (lbs)	Notes
	SOHC	87.0 x 78.0	1854	Alum, Crossflow	2	Unrestricted	1900	
	SOHC	90.0 x 78.0	1985	Alum, Crossflow	2	Unrestricted	2000	
	DOHC	90.0 x 78.0	1985	Alum, Crossflow	4	33mm SIR	2000	

GT3 Cars - SCION

Model	Years	Body Style	Drive-line	Wheel-base (in)	Notes
tC	05-	2dr	FWD	93.7	May use any class legal Toyota engine.

GT3 Cars - TOYOTA

Model	Years	Body Style	Drive-line	Wheel-base (in)	Notes
Celica	94-99	2dr	FWD	99.4	
Celica	00-05	2dr	FWD	102.4/93.7	
Celica Sport, Coupe GT, ST, Liftback GT	NA	2dr	FWD	98.3	
Corolla	NA	2, 4dr	FWD	94.5/102.4 / 93.7	
MR-2	-89	2dr	RWD	91.3	

GT3 Cars - TOYOTA (cont.)

Model	Years	Body Style	Drive-line	Wheel-base (in)	Notes
MR-2	99-02	2dr	FWD	91.3	
Paseo	92-99	2dr	FWD	93.7	
Tercel	91-	4dr	FWD	95.3 / 93.7	

Engines - TOYOTA

Engine Family	Engine Type	Bore x Stroke (mm)	Disp. (cc)	Head Type	Valves/ Cyl.	Fuel Induction	Weight (lbs)	Notes
4AG	DOHC	81.0 x 77.0 alt. stroke: 85.5	1587	Alum, Crossflow	4	Unrestricted	1900 2000 w/ alt. stroke	
7AFE	DOHC	81.0 x 85.4	1762	Alum, Crossflow	4	33mm SIR	1950	Alternate heads 11101-16010 and 11101-16030.
	OHV	85.0 x 78.0	1770	Alum, Crossflow	2	Unrestricted	1800	2TG cyl. head allowed.
1ZZ	DOHC	79.0 x 89.1	1794	Alum, Crossflow	4	33mm SIR	1950	
3S	SOHC	84.2 x 90.1	1998	Alum, Crossflow	2	48mm w/ 42mm choke(s)	1820	
20R	SOHC	88.5 x 89.0	2189	Alum, Crossflow	2	Unrestricted	2180	
2AZ	DOHC	88.5 x 96.0	2362	Alum, Crossflow	4	33mm SIR	2280 2180 w/ 31mmSIR	
	DOHC	95.0 x 86.0	2438	Alum, Crossflow	4	33mm SIR	2280 2180 w/ 31mmSIR	Alt. head: #11101-75015.

GT3 Cars - TRIUMPH

Model	Years	Body Style	Drive-line	Wheel-base (in)	Notes
GT6, GT6+ & Mk III	-74	2dr	RWD	83.0	
TR-250 / TR-6	NA	2dr	RWD	88.0	Windshield may be removed and a low front hoop roll cage fitted.

Engines - TRIUMPH

Engine Family	Engine Type	Bore x Stroke (mm)	Disp. (cc)	Head Type	Valves/ Cyl.	Fuel Induction	Weight (lbs)	Notes
	OHV	74.7 x 75.9	1998	Iron, Non-Crossflow	2	(3) Weber 40 DCOE w/ 34mm choke(s)	1870	
	OHV	74.7 x 95.0	2498	Iron, Non-Crossflow	2	(3) 45mm w/ 40mm choke(s)	2080	

GT3 Cars - VOLKSWAGEN

Model	Years	Body Style	Drive-line	Wheel-base (in)	Notes
Beetle	98-01	2dr	FWD	98.9	
Corrado	NA	3dr	FWD	97.3	
Golf & GTI	NA	3, 5dr	FWD	97.3 / 98.9	
Jetta	NA	4dr	FWD	97.3	
Rabbit	75-84	3, 5dr	FWD	94.5	
Scirocco	NA	3dr	FWD	94.5	

Engines - VOLKSWAGEN

Engine Family	Engine Type	Bore x Stroke (mm)	Disp. (cc)	Head Type	Valves/ Cyl.	Fuel Induction	Weight (lbs)	Notes
	SOHC	79.5 x 86.4	1715	Alum, Non-Crossflow	2	(2) 45mm w/ 45mm choke(s)	1800	Alt. Eurospec Sports cyl. head may be used.
	SOHC	81.0 x 86.4	1780	Alum, Crossflow	2	(2) 45mm w/ 45mm choke(s)	1850	Alt. Eurospec Sports cyl. head may be used.
	DOHC	81.0 x 86.4	1780	Alum, Crossflow	4	45mm w/ 38mm choke(s)	2000	
	SOHC	82.5 x 92.8	1984	Alum, Crossflow	2	50mm w/ 50mm choke(s)	1750	Alt. Eurospec Sports cyl. head may be used.
	DOHC	82.5 x 92.8	1984	Alum, Crossflow	4	33mm SIR	2000	

GT3 Cars - VOLVO

Model	Years	Body Style	Drive-line	Wheel-base (in)	Notes
122S	NA	2dr	RWD	102.5	
142 / 142E	NA	2dr	RWD	102.5	
242 / 244DL	NA	2dr	RWD	104.0	
S40	NA	4dr	FWD	100.4	

Engines - VOLVO

Engine Family	Engine Type	Bore x Stroke (mm)	Disp. (cc)	Head Type	Valves/Cyl.	Fuel Induction	Weight (lbs)	Notes
	OHV	88.9 x 80.0	1986	Iron, Non-Crossflow	2	Unrestricted	1930	
B20	SOHC	92.0 x 80.0	2127	Alum, Crossflow	2	Unrestricted	2180	
B21	SOHC	96.0 x 80.0	2320	Alum, Crossflow	2	Unrestricted	2180	

GTL Cars - Acura

Model	Years	Body Style	Drive-line	Wheel-base (in)	Notes
Integra	(-93)	2dr	FWD	96.5	May use any class legal Honda engine.
Integra	(94-)	2dr	FWD	101.2	May use any class legal Honda engine.
RSX	(02-05)	2dr	FWD	96.5 / 101.2	May use any class legal Honda engine.

GTL Cars - ALFA ROMEO

Model	Years	Body Style	Drive-line	Wheel-base (in)	Notes
GT-1300 Junior	NA	2dr	RWD	92.5	
GTA Junior	NA	2dr	RWD	92.5	
Alfetta GT	NA	2dr	RWD	94.5	
Giulia 1300	NA	2dr	RWD	98.8	
Giulia 1300 TI	NA	2dr	RWD	98.8	
GTV 1600	NA	2dr	RWD	92.5	
GTV 1750 / 2000	NA	2dr	RWD	92.5	
Giulietta Spider / Giulia Spider	NA	2dr	RWD	86.6 / 88.6	
all Spider models	(-94)	2dr	RWD	88.6	

Engines - ALFA

Engine Family	Engine Type	Bore x Stroke (mm)	Disp. (cc)	Head Type	Valves/ Cyl.	Fuel Induction	Weight (lbs)	Notes
	DOHC	78.0 x 67.5	1130	Alum, Crossflow	2	Unrestricted	1655	
	DOHC	74.0 x 75.0	1290	Alum, Crossflow	2	Unrestricted	1655	

Engines - ALFA (cont.)								
Engine Family	Engine Type	Bore x Stroke (mm)	Disp. (cc)	Head Type	Valves/ Cyl.	Fuel Induction	Weight (lbs)	Notes
	DOHC	80.0 x 67.5	1357	Alum, Crossflow	2	Unrestricted	1655	
	DOHC	78.0 x 82.0	1570	Alum, Crossflow	2	25mm SIR	1910	
	DOHC	80.0 x 75.0	1508	Alum, Crossflow	2	25mm SIR	1850	
	DOHC	80.0 x 88.5	1779	Alum, Crossflow	2	25mm SIR	1920	Alt. head: 19510-01053-04 (twin plug).
GTL Cars - AMC								
Model	Years	Body Style	Drive-line	Wheel-base (in)	Notes			
AMC/Renault Alliance	NA	3dr	FWD	93.5				
AMC/Renault Encore	NA	2dr	FWD	93.5				
Engines - AMC								
Engine Family	Engine Type	Bore x Stroke (mm)	Disp. (cc)	Head Type	Valves/ Cyl.	Fuel Induction	Weight (lbs)	Notes
	OHV	73.0 x 77.0	1296	Alum, Crossflow	2	Unrestricted	1712	Alternate crossflow head #7700597627.
	OHV	76.0 x 77.0	1397	Alum, Crossflow	2	Unrestricted	1807	Alternate crossflow head #7700597627.
GTL Cars - BLMI								
Model	Years	Body Style	Drive-line	Wheel-base (in)	Notes			
Austin-Healey Sprite	NA	2dr	RWD	80.0				
MG Midget	NA	2dr	RWD	80.0				
Mini Cooper	NA	2dr	FWD	80.2				

GTL Cars - BLMI (cont.)								
Model	Years	Body Style	Drive-line	Wheel-base (in)	Notes			
Austin America	NA	2dr	FWD	93.5				
BMW Mini	02-05	2dr	FWD	97.1				
Triumph Spitfire	NA	2dr	RWD	83.0				
Engines - BLMI								
Engine Family	Engine Type	Bore x Stroke (mm)	Disp. (cc)	Head Type	Valves/ Cyl.	Fuel Induction	Weight (lbs)	Notes
	OHV	62.992 x 76.2	948	Iron, non-Crossflow	2	Unrestricted	1210	RWD add 50 lbs.
	OHV	70.6 x 61.91	970	Iron, non-Crossflow	2	Unrestricted	1236	RWD add 50 lbs. Reduce by 100 lbs with original suspension and 10" wheels. Front and rear body seams may be removed. Pierce/PBS aluminum cylinder head allowed.
	OHV	70.6 x 68.26	1071	Iron, non-Crossflow	2	Unrestricted	1331	RWD add 50 lbs. Reduce by 100 lbs with original suspension and 10" wheels. Front and rear body seams may be removed. Pierce/PBS aluminum cylinder head allowed.
	OHV	64.516 x 83.82	1098	Iron, non-Crossflow	2	Unrestricted	1380	RWD add 50 lbs.
	OHV	69.34 x 76.2	1147	Iron, non-Crossflow	2	Unrestricted	1580	
	OHV	2.78 x 3.20 (70.6 x 81.33) alt. bore: 73.5 max. or 74.0 max.	1275 1380 1399	Iron, non-Crossflow	2	Unrestricted	1569 1380 @ 1648 1399 @ 1708	RWD add 50 lbs. Roll cage meeting requirements for cars under 1500lbs are acceptable for cars registered prior to 1/1/82. Reduce by 100 lbs with original suspension and 10" wheels. Front and rear body seams may be removed. Pierce/PBS aluminum cylinder head allowed.
	OHV	73.66 x 75.997	1296	Iron, non-crossflow	2	Unrestricted	1730	RWD add 50 lbs.
	OHV	73.66 x 87.376	1493	Iron, non-crossflow	2	25mm SIR	1780	RWD add 50 lbs.
W10B16	SOHC	77.0 x 85.8	1598	Alum, Crossflow	4	24mm SIR	2000	

GTL Cars - BMW								
Model	Years	Body Style	Drive-line	Wheel-base (in)	Notes			
1600-2 / 1602	NA	2dr	RWD	98.5				
Engines - BMW								
Engine Family	Engine Type	Bore x Stroke (mm)	Disp. (cc)	Head Type	Valves/ Cyl.	Fuel Induction	Weight (lbs)	Notes
	SOHC	84.0 x 71.0	1573	Alum, Crossflow	2	25mm SIR	1918	
GTL Cars - DODGE								
Model	Years	Body Style	Drive-line	Wheel-base (in)	Notes			
Colt Coupe	NA	2dr	FWD	96.0	Mitsubishi bodywork allowed.			
Omni	NA	2dr	FWD	99.2				
024	1978	2dr	FWD	96.7				
Engines - DODGE								
Engine Family	Engine Type	Bore x Stroke (mm)	Disp. (cc)	Head Type	Valves/ Cyl.	Fuel Induction	Weight (lbs)	Notes
	SOHC	79.0 x 86.0	1597	Alum, Crossflow	2	25mm SIR	1910	
	SOHC	79.5 x 86.4 alt. bore: 81.0	1715	Alum, Crossflow, non-Crossflow	2	25mm SIR	1920 1950 w/ alt. bore	
GTL Cars - FIAT								
Model	Years	Body Style	Drive-line	Wheel-base (in)	Notes			
124 Sport Coupe	NA	2dr	RWD	95.3				
124 Special	NA	2dr	RWD	95.3				

GTL Cars - FIAT (cont.)

Model	Years	Body Style	Drive-line	Wheel-base (in)	Notes
128 Coupe	NA	2dr	FWD	87.5	
128	NA	2dr	FWD	96.4	
131 Coupe	NA	2dr	RWD	98.0	
131 Sedan	NA	4dr	RWD	98.0	
X19	NA	2dr	RWD	86.7	Removable roof panel must be in place

Engines - FIAT

Engine Family	Engine Type	Bore x Stroke (mm)	Disp. (cc)	Head Type	Valves/Cyl.	Fuel Induction	Weight (lbs)	Notes
	SOHC	80.0 x 55.5	1116	Alum, Non-Crossflow	2	Unrestricted	1417	
	SOHC	86.0 x 55.5	1290	Alum, Non-Crossflow	2	Unrestricted	1645	Roll cage meeting requirements for cars under 1500 lbs are acceptable for cars registered prior to 1/1/82.
1300 w/ 1500 block	SOHC	86.0 x 55.5	1290	Alum, Non-Crossflow	2	Unrestricted	1670	
	OHV	80.0 x 71.5	1438	Alum, Non-Crossflow	2	25mm SIR	1902	
	SOHC	86.4 x 64.0	1498	Alum, Non-Crossflow	2	25mm SIR	1815	
	DOHC	80.0 x 79.2	1592	Alum, Crossflow	2	25mm SIR	1918	
	DOHC	80.0 x 80.0	1608	Alum, Crossflow	2	25mm SIR	1920	
	DOHC	84.0 x 79.2	1756	Alum, Crossflow	2	25mm SIR	1920	

GTL Cars - FORD								
Model	Years	Body Style	Drive-line	Wheel-base (in)	Notes			
Anglia Super	NA	2dr	RWD	90.5				
Cortina GT	64-68	2dr	RWD	98.0				
Escort Super	68-74	2dr	RWD	96.0				
Escort Lynx, EXP, LN7	81-90 1982	2dr	FWD	94.2				
Escort Mexico	70-74	2dr	RWD	96.0				
Fiesta	78-80	2dr	FWD	90.0				
Pinto	NA	2dr	RWD	94.0	Non-tube frame track: (F&R) 60.52"			
Engines - FORD								
Engine Family	Engine Type	Bore x Stroke (mm)	Disp. (cc)	Head Type	Valves/Cyl.	Fuel Induction	Weight (lbs)	Notes
	OHV	3.19 x 2.29	1198	Iron, Non-crossflow	2	Unrestricted	1598	Alternate 1500cc Block: casting # 27333E6015 @ +23 lbs.
	OHV	3.19 x 2.48	1297	Iron, Non crossflow	2	Unrestricted	1598	Alternate 1500cc Block: casting # 27333E6015 w/ 23 lb penalty, 1600cc block w/ 25 lb penalty. Any Formula Ford cyl. head may be used, including aluminum version w/ 75 lb. penalty.
	OHV	81.0 x 73.2	1499	Iron, Non crossflow	2	25mm SIR	1902	
	OHV	81.0 x 77.5	1598	Iron, Crossflow	2	25mm SIR	1902	Any Formula Ford cylinder head may be used, including aluminum version.
	SOHC	80.0 x 79.5	1598	Alum, Crossflow	2	25mm SIR	1918	
Zetec	DOHC	80.6 x 88.0	1796	Alum, Crossflow	4	24mm SIR	2050	Alt. 2.0L cyl block may be sleeved to specified bore size.

GTL Cars - HONDA

Model	Years	Body Style	Drive-line	Wheel-base (in)	Notes
Civic	73-79	3dr	FWD	86.6	
Civic	80-87	3dr	FWD	88.6	
CRX	84-87	3dr	FWD	86.6	Hood bulge permitted, no openings.
Civic	84-87	2dr, 3dr	FWD	93.7	Hood bulge permitted, no openings.
Civic	84-87	4dr	FWD	96.5	Hood bulge permitted, no openings.
CRX	88-91	3dr	FWD	90.6	Hood bulge permitted, no openings.
Civic	88-91	3dr	FWD	98.4	Hood bulge permitted, no openings.
Civic	92-95	2dr	FWD	103.2	Hood bulge permitted, no openings.
Civic Del Sol	93-97	2dr	FWD	93.3	
Civic	96-06	2dr	FWD	103.2	Hood bulge permitted, no openings.

Engines - HONDA

Engine Family	Engine Type	Bore x Stroke (mm)	Disp. (cc)	Head Type	Valves/ Cyl.	Fuel Induction	Weight (lbs)	Notes
EB	SOHC	70.0 x 76.0	1170	Alum, Crossflow	2	Unrestricted	1640	Alt heads: #12100-634-000.
EB	SOHC	72.0 x 76.0	1237	Alum, Crossflow	2	Unrestricted	1726	Alt heads: #12100-634-000.
EN	SOHC	72.0 x 82.0	1335	Alum, Crossflow	3	24mm SIR	1769	Alt. Heads: #12100-PB9-000 (2 valve, Crossflow w/ unrestricted fuel induction), 12100-PA1-000.
EW	SOHC	74.0 x 78.0	1342	Alum, Crossflow	3	24mm SIR	1800	Alt. Heads: #12100-PE3-000 or 12100-PE7-000.
EW	SOHC	74.0 x 86.5	1488	Alum, Crossflow	3	24mm SIR	1900	Alt. Heads: #12100-PE3-000 or 12100-PE7-000.
D15	SOHC	75.0 x 84.5	1493	Alum, Crossflow	4	24mm SIR	2000	
D16	SOHC	75.0 x 90.0	1590	Alum, Crossflow	4	24mm SIR	2000	
D16A	DOHC	75.0 x 90.0	1590	Alum, Crossflow	4	24mm SIR	2000	

Engines - HONDA (cont.)								
Engine Family	Engine Type	Bore x Stroke (mm)	Disp. (cc)	Head Type	Valves/ Cyl.	Fuel Induction	Weight (lbs)	Notes
B16A	DOHC	81.0 x 77.4	1595	Alum, Crossflow	4	24mm SIR	2000	
B18	DOHC	81.0 x 87.2 81.0 x 89.0	1797 1834	Alum, Crossflow	4	24mm SIR	2050	
GTL Cars - LANCIA								
Model	Years	Body Style	Drive-line	Wheel-base (in)	Notes			
Scorpion	76-77	2dr	RWD	90.5	Trunk mounted fuel cell is permitted. Fabric roof panel may be replaced with alternate material. Non-tube frame track (R) 61.5".			
Engines - LANCIA								
Engine Family	Engine Type	Bore x Stroke (mm)	Disp. (cc)	Head Type	Valves/ Cyl.	Fuel Induction	Weight (lbs)	Notes
	DOHC	84.0 x 79.2	1756	Alum, Crossflow	2	25mm SIR	1920	
GTL Cars - LOTUS								
Model	Years	Body Style	Drive-line	Wheel-base (in)	Notes			
Cortina	64-66	2dr	RWD	97.5				
Cortina	67	2dr	RWD	98.0				
Elan S2, S4 (Rdstr, Cpe, Drphead)	NA	2dr	RWD	84.0	Windshield may be removed and a low front hoop roll cage may be fitted.			
Europa		2dr	RWD	91.0				
Engines - LOTUS								
Engine Family	Engine Type	Bore x Stroke (mm)	Disp. (cc)	Head Type	Valves/ Cyl.	Fuel Induction	Weight (lbs)	Notes
	DOHC	82.6 x 73.0	1558	Alum, Crossflow	2	25mm SIR	1918	

GTL Cars - MAZDA

Model	Years	Body Style	Drive-line	Wheel-base (in)	Notes
Protégé	1999	2dr	FWD	96.5/98.4/ 102.8	
Protégé 5	2002	5dr	FWD	96.3/102.8	OEM roof spoiler is permitted (P/N:B25T-51-960C-XX, "XX" = color code)
GLC	NA	2dr	FWD	93.1/98.4	
MX-3	92-94	2dr	FWD	91.1/96.3	
MX-5 / Miata	90-05	2dr	RWD	89.2	
323	88-91	2dr	FWD	94.5	
3		2dr	FWD	97.0	
RX-3		2dr	RWD	91.0	
RX-7		2dr	RWD	95.3, 95.5, 95.7	Non-tube frame track (F) 60.7" (R) 60.3".

Engines - MAZDA

Engine Family	Engine Type	Bore x Stroke (mm)	Disp. (cc)	Head Type	Valves/ Cyl.	Fuel Induction	Weight (lbs)	Notes
	SOHC	73.0 x 76.0	1272	Alum, Crossflow	2	Unrestricted	1730	1500cc block and head w/1300 (1365)cc crankshaft (#E301-11-301 or equivalent) is permitted. Alt. head: # E515-10-100B.
	SOHC	77.0 x 69.6	1296	Alum, Crossflow	2	Unrestricted	1693	1500cc block and head w/1300 (1365)cc crankshaft (#E301-11-301 or equivalent) is permitted. Alt. head: # E515-10-100B.
	SOHC	77.0 x 80.0	1490	Alum, Crossflow	2	25mm SIR	1830	Alt. Head: #E515-10-100B.
	SOHC	78.0 x 83.6	1597	Alum, Crossflow	2	25mm SIR	1910	
	DOHC	78.0 x 83.8	1597	Alum, Crossflow	4	24mm SIR	2000	
	DOHC	83.0 x 85.0	1839	Alum, Crossflow	4	24mm SIR	2050	
12A	Street Port		2292			27mm SIR	1950	Engine setback from the front spindle centerline to the front spark plug is 4.5".

GTL Cars - NISSAN

Model	Years	Body Style	Drive-line	Wheel-base (in)	Notes
PL510	68-73	2dr, 4dr	RWD	95.3	
1200 (B110)	70-73	2dr	RWD	90.6	
B210	74-78	2dr, 3dr, 4dr	RWD	92.1	
210 (B310)	79-82	2dr, 3dr, 4dr	RWD	92.1 or 94.2	
SRL 311U	NA	2dr	RWD	89.9	
Pulsar (N12)	83-86	3dr	FWD	95.1	
Pulsar (KN13)	87-90	3dr	FWD	95.1	
Sentra (B11)	82-85	2dr, 3dr, 4dr	FWD	94.5	
Sentra (B12)	86-90	2dr, 3dr, 4dr	FWD	94.5	
Sentra (B13)	91-94	2dr, 4dr	FWD	95.7	
200SX SE-R (B14)	95-97	2dr	FWD	95.7 or 99.8	
240SX (S13/S14)	NA	2dr	RWD	97.5	
Sentra SE-R (B15U)	2002	4dr	FWD	95.7 or 99.8	

Engines - NISSAN

Engine Family	Engine Type	Bore x Stroke (mm)	Disp. (cc)	Head Type	Valves/ Cyl.	Fuel Induction	Weight (lbs)	Notes
A12	OHV	73.0 x 70.0 alt. bore: 75.2 max.	1171	Alum, Non-crossflow	2	Unrestricted	1598 (1638 w/ alt. bore)	Alt heads: #11041-H2303, 11041-H5704, 11041-H9204.
A12A	OHV	75.0 x 70.0 alt. bore: 77.2 max.	1237	Alum, Non-crossflow	2	Unrestricted	1693 (1733 w/ alt. bore)	Alt heads: #11041-H2303, 11041-H5704, 11041-H9204. 1237cc with A14 Block @1716 lbs.

Engines - NISSAN (cont.)

Engine Family	Engine Type	Bore x Stroke (mm)	Disp. (cc)	Head Type	Valves/ Cyl.	Fuel Induction	Weight (lbs)	Notes
A12A w/A14 Block	OHV	75.0 x 70.0 alt. bore: 77.2 max.	1237	Alum, Non- crossflow	2	Unrestricted	1716 (1756 w/ alt. bore)	Alt heads: #11041-H2303, 11041-H5704, 11041-H9204.
A13	OHV	73.0 x 77.0 alt. bore: 75.2 max.	1288	Alum, Non- crossflow	2	Unrestricted	1769 (1809 w/ alt. bore)	Alt heads: #11041-H2303, 11041-H5704, 11041-H9204.
A14	OHV	76.0 x 77.0	1397	Alum, Non- crossflow	2	25mm SIR	1780	Alt heads: #11041-H2303, 11041-H5704, 11041-H9204.
A15	OHV	76.0 x 82.0	1488	Alum, Non- crossflow	2	25mm SIR	1850	Alt heads: #11041-H2303, 11041-H5704, 11041-H9204.
E15	SOHC	76.0 x 82.0	1488	Alum, Crossflow	2	25mm SIR	1850	Alt head: #11041-15M00.
E16	SOHC	76.0 x 88.0	1597	Alum, Crossflow	2	25mm SIR	1918	Alt heads: #11041-15M00, 11041-17M00.
GA16	DOHC	76.0 x 88.0	1597	Alum, Crossflow	4	24mm SIR	2000	
L16	SOHC	83.0 x 73.7	1595	Alum, Non- crossflow	2	25mm SIR	1918	Alt Heads: #11041-22010, 11041-U0600A, 11041-U0602-SV, 11041-N7120, 11041-21901.
SR16VE	DOHC	86.0 x 68.7	1596	Alum, Crossflow	4	24mm SIR	2000	Alt. Heads: #11040-1N591.
QG18DE	DOHC	80.0 x 88.0	1769	Alum, Crossflow	4	24mm SIR	2050	
L18	SOHC	85.0 x 78.0	1770	Alum, Non- Crossflow	2	25mm SIR	1920	#11041-22010, 11041-U0600-A, 11041-U0602-SV, 11041-21901, 11041-N7120.
CA18	SOHC	83.0 x 83.6	1809	Alum, Crossflow	2	25mm SIR	1920	
CA18DE	DOHC	83.0 x 83.6	1809	Alum, Crossflow	4	24mm SIR	2050	

GTL Cars - OPEL								
Model	Years	Body Style	Drive-line	Wheel-base (in)	Notes			
1900	1995	2dr	RWD	95.7				
Mk 51		2dr	RWD	95.7				
Mk 53		2dr	RWD	95.7				
Sport Coupe Rallye		2dr	RWD	95.7				
Mk 57R		2dr	RWD	95.7				
Sport Coupe		2dr	RWD					
Mk 77		2dr	RWD	95.7				
GT 1900	1995	2dr	RWD	95.7				
Engines - OPEL								
Engine Family	Engine Type	Bore x Stroke (mm)	Disp. (cc)	Head Type	Valves/ Cyl.	Fuel Induction	Weight (lbs)	Notes
	SOHC	93.0 x 69.9	1897	Iron, Non-crossflow	2	25mm SIR	1920	
GTL Cars - PORSCHE								
Model	Years	Body Style	Drive-line	Wheel-base (in)	Notes			
914-4		2dr	RWD	96.5				
Engines - PORSCHE								
Engine Family	Engine Type	Bore x Stroke (mm)	Disp. (cc)	Head Type	Valves/ Cyl.	Fuel Induction	Weight (lbs)	Notes
	OHV	93.0 x 66.0	1795	Alum, Crossflow	2	25mm SIR	1920	Material may be added as required only to relocate spark plug hole as per 2.0L head. Alum crossflow head from 2.0L may be utilized.
	OHV	90.0 x 66.0	1679	Alum, Crossflow	2	25mm SIR	1920	Material may be added as required only to relocate spark plug hole as per 2.0L head. Alum crossflow head from 2.0L may be utilized.

GTL Cars - RENAULT

Model	Years	Body Style	Drive-line	Wheel-base (in)	Notes
R5	NA	2dr	FWD	94.6	Left Hand Drive Wheelbase - 95.8.
R1228	1978	2dr	FWD	96.6	Left Hand Drive Wheelbase - 95.8.
LeCar	78-79	2dr	FWD	94.6	Left Hand Drive Wheelbase - 95.8. (Firewall modifications permitted with use of alt. head.)

Engines - RENAULT

Engine Family	Engine Type	Bore x Stroke (mm)	Disp. (cc)	Head Type	Valves/ Cyl.	Fuel Induction	Weight (lbs)	Notes
	OHV	73.0 x 77.0	1289	Alum, Non-crossflow	2	Unrestricted	1712	Alt Head: #7700597627.
	OHV	76.0 x 77.0	1397	Alum, Non-crossflow	2	25mm SIR	1850	Alt Head: #7700597627.

GTL Cars - SAAB

Model	Years	Body Style	Drive-line	Wheel-base (in)	Notes
Sedan	-1964	4dr	FWD	98.4	
Sonnet	NA	2dr	FWD	84.6	
Sonnet III	NA	2dr	FWD	84.6	

Engines - SAAB

Engine Family	Engine Type	Bore x Stroke (mm)	Disp. (cc)	Head Type	Valves/ Cyl.	Fuel Induction	Weight (lbs)	Notes
	OHV	89.9 x 58.9	1496	Iron, crossflow	2	25mm SIR	1880	Intake manifold: #379050.
	OHV	89.9 x 66.8	1696	Iron, crossflow	2	25mm SIR	1920	Intake manifold: #379050.

GTL Cars - SCION								
Model	Years	Body Style	Drive-line	Wheel-base (in)	Notes			
Xa	(05-06)	5dr	FWD	93.3	May use any class legal Toyota engine.			
GTL Cars - SUBARU								
Model	Years	Body Style	Drive-line	Wheel-base (in)	Notes			
GL Coupe	NA	2dr	FWD	96.6	CVT transmission prohibited.			
Justy (2WD)	88-94	2dr	FWD	89.9	CVT transmission prohibited.			
Engines - SUBARU								
Engine Family	Engine Type	Bore x Stroke (mm)	Disp. (cc)	Head Type	Valves/ Cyl.	Fuel Induction	Weight (lbs)	Notes
	SOHC	78.0 x 83.0	1189	Alum, Crossflow	3	Unrestricted	1593	
	OHV	3.23 x 2.36	1267	Alum, Non-crossflow	2	Unrestricted	1724	
GTL Cars - SUZUKI								
Model	Years	Body Style	Drive-line	Wheel-base (in)	Notes			
Swift	89-94	4dr	FWD	93.1				
Swift	95-01	2dr	FWD	93.1				
Engines - SUZUKI								
Engine Family	Engine Type	Bore x Stroke (mm)	Disp. (cc)	Head Type	Valves/ Cyl.	Fuel Induction	Weight (lbs)	Notes
	DOHC	74.0 x 75.5	1299	Alum, Crossflow	4	24mm SIR	1830	

GTL Cars - TOYOTA

Model	Years	Body Style	Drive-line	Wheel-base (in)	Notes
Celica	00-05	2dr	FWD	102.4 or 93.7	
Corolla 1200	NA	2dr	RWD	90.0 or 91.9	Rollcage meeting requirements for cars under 1500lbs are acceptable for cars registered prior to 1/1/82
Corolla SR-5	-74	2dr	RWD	91.9	
Corolla SR-5	75	2dr	RWD	93.3	
Corolla Sport Coupe & Lift Back	76-79	2dr, 3dr, 4dr		93.3	
Corolla	80-83	2dr, 3dr	RWD	94.5	
Corolla	84	2dr, 3dr, 4dr	RWD	90.6	
Corolla Sport / Sport Coupe (8V)	84-87	2dr, 3dr	RWD	94.5	
Corolla SR-5 / Sport Coupe	88	2dr	FWD	95.7	
Starlet	81	3dr	RWD	90.6	
Tercel	91-	2dr, 3dr	FWD	93.7	
Paseo	92-99	3dr	FWD	93.7	

Engines - TOYOTA

Engine Family	Engine Type	Bore x Stroke (mm)	Disp. (cc)	Head Type	Valves/ Cyl.	Fuel Induction	Weight (lbs)	Notes
3K	OHV	75.0 x 66.0	1166	Alum, Non-Crossflow	2	Unrestricted	1660	
4K	OHV	75.0 x 73.0	1290	Alum, Non-Crossflow	2	Unrestricted	1693	
	OHV	77.5 x 77.0	1452	Alum, Non-Crossflow	2	25mm SIR	1880	
5K	OHV	80.5 x 73.0	1486	Alum, Non-Crossflow	2	25mm SIR	1750	
4A-C/L/LC	SOHC	81.0 x 77.0	1587	Alum, Non-Crossflow	2	25mm SIR	1902	

Engines - TOYOTA (cont.)

Engine Family	Engine Type	Bore x Stroke (mm)	Disp. (cc)	Head Type	Valves/ Cyl.	Fuel Induction	Weight (lbs)	Notes
2T-C	OHV	85.0 x 70.0	1588	Alum, Crossflow	2	25mm SIR	1897	
7AFE	DOHC	81.0 x 85.4	1762	Alum, Crossflow	4	24mm SIR	2050	
1ZZ	DOHC	79.0 x 91.5	1794	Alum, Crossflow	4	24mm SIR	2050	
3TC	OHV	85.0 x 78.0	1770	Alum, Crossflow	2	25mm SIR	1920	
4AG	DOHC	81.0 x 77.0	1587	Alum, Crossflow	4	24mm SIR	2000	

GTL Cars - VOLKSWAGEN

Model	Years	Body Style	Drive-line	Wheel-base (in)	Notes
1300/1500/ 1600 (Bug)	65-69	2dr	rear engine	94.5	
1600 (Bug) / Super Beetle	70-77	2dr	rear engine	95.3	
Rabbit	75-84	3dr, 5dr	FWD	94.5	
Scirocco		3dr	FWD	94.5	
Corrado		3dr	FWD	94.5	
Golf	85-	3dr, 5dr	FWD	94.5	
Golf Mark - IV		3dr, 5dr	FWD	98.2	
Jetta Mark - IV		4dr	FWD	98.2	
Beetle	98-01	3dr	FWD		

Engines - VOLKSWAGEN

Engine Family	Engine Type	Bore x Stroke (mm)	Disp. (cc)	Head Type	Valves/ Cyl.	Fuel Induction	Weight (lbs)	Notes
air cooled, flat 4	OHV	77.0 x 69.0	1285	Alum, Non-Crossflow	2	Unrestricted	1569	Siamesed intake port.
air cooled, flat 4	OHV	77.0 x 69.0	1285	Alum, Non-Crossflow	2	Unrestricted	1664	Dual intake port.
air cooled, flat 4	OHV	83.0 x 69.0	1493	Alum, Crossflow	2	25mm SIR	1880	Alt. Heads: #043-101-375H.
air cooled, flat 4	OHV	85.5 x 69.0	1584	Alum, Crossflow	2	25mm SIR	1880	Alt. Heads: #043-101-375H.
water cooled	SOHC	79.5 x 73.4	1457	Alum, non-crossflow	2	25mm SIR	1850	
water cooled	SOHC	76.5 x 80.0	1471	Alum, Non-Crossflow	2	25mm SIR	1850	Alt. Heads: #026-103-373G, 049-103-351C, Eurospec Sports head.
water cooled	SOHC	79.5 x 80.0	1588	Alum, Non-Crossflow	2	25mm SIR	1910	Alt. Heads: #026-103-373G, 049-103-351C, Eurospec Sports head.
air cooled	OHV	90.0 x 66.0	1679	Alum, Crossflow	2	25mm SIR	1900	Alt. Heads: #043-101-375-H.
water cooled	SOHC	79.5 x 86.4	1715	Alum, Non-Crossflow	2	25mm SIR	1950	Alt. Eurospec cyl. head may be used.
water cooled	SOHC	81.0 x 86.4	1780	Alum, Non-Crossflow	2	25mm SIR	1950	Alt. Eurospec cyl. head may be used.
water cooled	DOHC	81.0 x 86.4	1780	Alum, Crossflow	4	24mm SIR	2050	
air cooled	OHV	93.0 x 66.0	1795	Alum, Crossflow	2	25mm SIR	1950	Alt. Heads: #043-101-375-H.

GTL Cars - YUGO

Model	Years	Body Style	Drive-line	Wheel-base (in)	Notes
GV	86-89	2dr	RWD	84.6	

Engines - YUGO

Engine Family	Engine Type	Bore x Stroke (mm)	Disp. (cc)	Head Type	Valves/ Cyl.	Fuel Induction	Weight (lbs)	Notes
	SOHC	80.0 x 55.5	1116	Alum, Non-Crossflow	2	27mm SIR	1645	